

***ECD 7.5/ECI 7.5,  
ECD 15/ECI 15, ECD 30/ECI 30,  
ECD 60/ECI 60, ECD 90/ECI 90,  
ECD 120/ECI 120  
Conventional Roller Beds***

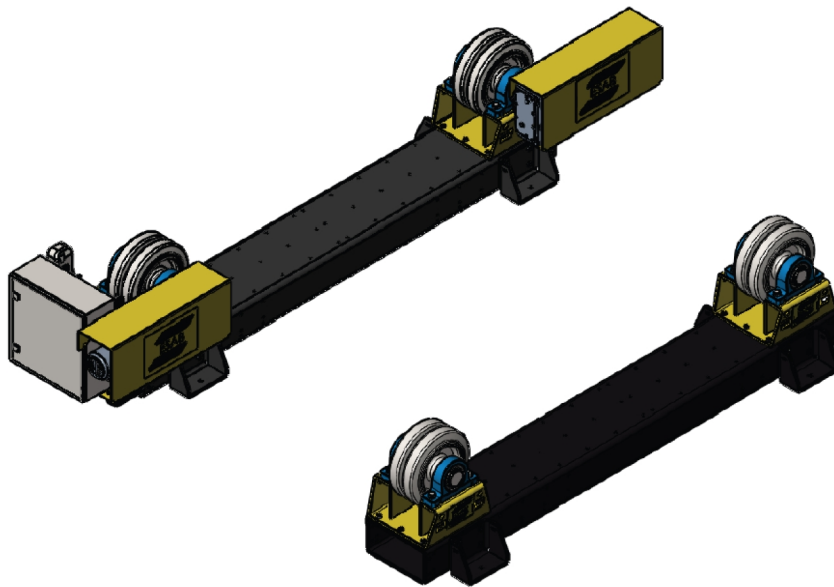

**Instruction manual**



## EU DECLARATION OF CONFORMITY

According to  
The Machinery Directive 2006/42/EC, entering into force 17 May 2006  
The EMC Directive 2014/30/EU, entering into force 20 April 2016  
The RoHS Directive 2011/65/EU, entering into force 2 January 2013

### Type of equipment

Welding handling equipment, Conventional Roller Bed

### Type designation

ECD 15, ECD 30, ECD 60, ECD 90, ECD 120 (Drive unit) from serial number 950 xxx xxxx (2019 w50)  
ECD 7.5, ECD 15, ECD 30, ECD 60, ECD 90, ECD 120 (Drive unit) from serial number LX130 xxxx xxxx (2021 w30)

ECI 15, ECI 30, ECI 60, ECI 90, ECI 120 (Idler unit) from serial number 950 xxx xxxx (2019 w50)  
ECI 7.5 (Idler unit) from serial number LX130 xxxx xxxx (2021 w30)

### Brand name or trade mark

ESAB

### Manufacturer or his authorised representative established within the EEA

#### Name, address, and telephone No:

ESAB AB Welding Automation  
SE-69581 Laxå, Sweden  
Phone: +46 (0)584 81000, [www.esab.com](http://www.esab.com)

### The following harmonised standard in force within the EEA has been used in the design:

EN 12100:2010 EN 61000-6-2:2019  
EN 60204-1:2018 EN 61000-6-4:2019

### Additional Information:

Restrictive use, Class A equipment, intended for use in location other than residential

By signing this document, the undersigned declares as manufacturer, or the manufacturer's authorised representative established within the EEA, that the equipment in question complies with the safety requirements stated above.

Date	Signature	Position
Gothenburg		
2023-03-13	Peter Kjällström	Director Welding Automation

CE 2023

<b>1</b>	<b>SAFETY</b> .....	<b>5</b>
1.1	Meaning of symbols .....	5
1.2	Non-compliant operation .....	5
1.3	Safety precautions .....	5
<b>2</b>	<b>INTRODUCTION</b> .....	<b>9</b>
2.1	Equipment .....	9
2.2	Purpose and function of roller beds .....	9
2.3	Terminology used in this manual .....	9
<b>3</b>	<b>TECHNICAL DATA</b> .....	<b>10</b>
3.1	<b>ECD/ECI 7.5</b> .....	<b>10</b>
3.1.1	Drive unit ECD 7.5 .....	10
3.1.2	Idler unit ECI 7.5 .....	11
3.2	<b>ECD/ECI 15</b> .....	<b>12</b>
3.2.1	Drive unit ECD 15 .....	12
3.2.2	Idler unit ECI 15 .....	13
3.3	<b>ECD/ECI 30</b> .....	<b>14</b>
3.3.1	Drive unit ECD 30 .....	14
3.3.2	Idler unit ECI 30 .....	15
3.4	<b>ECD/ECI 60</b> .....	<b>16</b>
3.4.1	Drive unit ECD 60 .....	16
3.4.2	Idler unit ECI 60 .....	17
3.5	<b>ECD/ECI 90</b> .....	<b>18</b>
3.5.1	Drive unit ECD 90 .....	18
3.5.2	Idler unit ECI 90 .....	19
3.6	<b>ECD/ECI 120</b> .....	<b>20</b>
3.6.1	Drive unit ECD 120 .....	20
3.6.2	Idler unit ECI 120 .....	21
<b>4</b>	<b>INSTALLATION</b> .....	<b>22</b>
4.1	Location .....	22
4.2	Lifting instructions .....	22
4.3	Adjusting the wheel stands .....	23
4.4	Adjusting the included angle .....	24
4.5	Installation procedure .....	24
4.6	PEK setup .....	25
4.7	Roller bed configurations .....	27
<b>5</b>	<b>OPERATION</b> .....	<b>28</b>
5.1	Roller bed details .....	28
5.2	Control panel .....	28
5.3	Wireless remote - control pendant .....	29
5.4	Switch the mains power on .....	30
5.5	Operating the roller beds .....	31
5.6	Operation safety .....	31
5.7	Welding .....	33
5.8	Stopping the roller beds .....	33
<b>6</b>	<b>MAINTENANCE</b> .....	<b>34</b>

TABLE OF CONTENTS

---

6.1	General .....	34
6.2	Storage .....	34
6.3	Repair and maintenance .....	34
6.4	Cleaning .....	35
6.5	Breakdowns .....	35
6.6	Gearmotors .....	35
	6.6.1 Gearmotors inspection and maintenance .....	35
	6.6.2 Gearbox lubrication .....	35
6.7	Inverters .....	36
6.8	Bearings .....	36
6.9	PU wheels .....	36
7	TROUBLESHOOTING .....	38
8	ORDERING SPARE PARTS .....	39
	WIRING DIAGRAM .....	40
	ORDERING NUMBERS .....	45
	ACCESSORIES .....	46
	SPARE PARTS .....	47
	SPARE PARTS - ECD 7.5 Mechanical parts list - Drive section .....	48
	SPARE PARTS - ECI 7.5 Mechanical parts list - Idler section .....	49
	SPARE PARTS - ECD 15 Mechanical parts list - Drive section .....	50
	SPARE PARTS - ECI 15 Mechanical parts list - Idler section .....	52
	SPARE PARTS - ECD 30 Mechanical parts list - Drive section .....	53
	SPARE PARTS - ECI 30 Mechanical parts list - Idler section .....	55
	SPARE PARTS - ECD 60 Mechanical parts list - Drive section .....	56
	SPARE PARTS - ECI 60 Mechanical parts list - Idler section .....	58
	SPARE PARTS - ECD 90 Mechanical parts list - Drive section .....	59
	SPARE PARTS - ECI 90 Mechanical parts list - Idler section .....	61
	SPARE PARTS - ECD 120 Mechanical parts list - Drive section .....	62
	SPARE PARTS - ECI 120 Mechanical parts list - Idler section .....	64
	SPARE PARTS - Control cabinet .....	65
	SPARE PARTS - Electrical parts - Control cabinet .....	67
	SPARE PARTS - Wireless control system .....	68



# 1 SAFETY

## 1.1 Meaning of symbols

As used throughout this manual: Means Attention! Be Alert!



### **DANGER!**

Means immediate hazards which, if not avoided, will result in immediate, serious personal injury or loss of life.



### **WARNING!**

Means potential hazards which could result in personal injury or loss of life.



### **CAUTION!**

Means hazards which could result in minor personal injury.



### **WARNING!**

Before use, read and understand the instruction manual and follow all labels, employer's safety practices and Safety Data Sheets (SDSs).



## 1.2 Non-compliant operation



### **CAUTION!**

These roller beds are not suitable for the following:

- Any vessel which is heavier than the maximum weight limit of the roller beds.
- Any vessel that is larger/smaller than the maximum/minimum diameter that can be supported.
- If the roller beds have polyurethane or rubber tires Do not use on preheated vessels above 60 °C.

## 1.3 Safety precautions

Users of ESAB equipment have the ultimate responsibility for ensuring that anyone who works on or near the equipment observes all the relevant safety precautions. Safety precautions must meet the requirements that apply to this type of equipment. The following recommendations should be observed in addition to the standard regulations that apply to the workplace.

All work must be carried out by trained personnel well-acquainted with the operation of the equipment. Incorrect operation of the equipment may lead to hazardous situations which can result in injury to the operator and damage to the equipment.

1. Anyone who uses the equipment must be familiar with:
  - its operation
  - location of emergency stops
  - its function
  - relevant safety precautions
  - welding and cutting or other applicable operation of the equipment
2. The operator must ensure that:
  - no unauthorised person is stationed within the working area of the equipment when it is started up
  - no-one is unprotected when the arc is struck or work is started with the equipment
3. The workplace must:
  - be suitable for the purpose
  - be free from drafts
4. Personal safety equipment:
  - Always wear recommended personal safety equipment, such as safety glasses, flame-proof clothing, safety gloves
  - Do not wear loose-fitting items, such as scarves, bracelets, rings, etc., which could become trapped or cause burns
5. General precautions:
  - Make sure the return cable is connected securely
  - Work on high voltage equipment **may only be carried out by a qualified electrician**
  - Appropriate fire extinguishing equipment must be clearly marked and close at hand
  - Lubrication and maintenance must **not** be carried out on the equipment during operation



### **WARNING!**

Arc welding and cutting can be injurious to yourself and others. Take precautions when welding and cutting.



### **ELECTRIC SHOCK - Can kill**

- Do not touch live electrical parts or electrodes with bare skin, wet gloves or wet clothing
- Insulate yourself from work and ground.
- Ensure your working position is safe



### **ELECTRIC AND MAGNETIC FIELDS - Can be dangerous to health**

- Welders having pacemakers should consult their physician before welding. EMF may interfere with some pacemakers.
- Exposure to EMF may have other health effects which are unknown.
- Welders should use the following procedures to minimize exposure to EMF:
  - Route the electrode and work cables together on the same side of your body. Secure them with tape when possible. Do not place your body between the torch and work cables. Never coil the torch or work cable around your body. Keep welding power source and cables as far away from your body as possible.
  - Connect the work cable to the workpiece as close as possible to the area being welded.



**FUMES AND GASES - Can be dangerous to health**

- Keep your head out of the fumes
- Use ventilation, extraction at the arc, or both, to take fumes and gases away from your breathing zone and the general area



**ARC RAYS - Can injure eyes and burn skin**

- Protect your eyes and body. Use the correct welding screen and filter lens and wear protective clothing
- Protect bystanders with suitable screens or curtains



**NOISE - Excessive noise can damage hearing**

Protect your ears. Use earmuffs or other hearing protection.



**MOVING PARTS - Can cause injuries**

- Keep all doors, panels and covers closed and securely in place. Have only qualified people remove covers for maintenance and troubleshooting as necessary. Reinstall panels or covers and close doors when service is finished and before starting the roller beds.



- Stop the roller beds before installing or connecting unit.
- Keep hands, hair, loose clothing and tools away from moving parts.



**FIRE HAZARD**

- Sparks (spatter) can cause fire. Make sure therefore that there are no inflammable materials nearby



**HOT SURFACE - Parts can burn**

- Do not touch parts bare handed.
- Allow cooling period before working on equipment.
- To handle hot parts, use proper tools and/or insulated welding gloves to prevent burns.

**MALFUNCTION - Call for expert assistance in the event of malfunction.**

**PROTECT YOURSELF AND OTHERS!**



**CAUTION!**

Class A equipment is not intended for use in residential locations where the electrical power is provided by the public low-voltage supply system. There may be potential difficulties in ensuring electromagnetic compatibility of class A equipment in those locations, due to conducted as well as radiated disturbances.

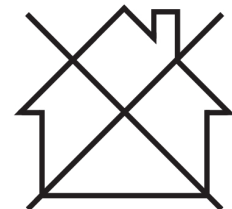



**NOTE!**  
**Dispose of electronic equipment at the recycling facility!**

In observance of European Directive 2012/19/EC on Waste Electrical and Electronic Equipment and its implementation in accordance with national law, electrical and/or electronic equipment that has reached the end of its life must be disposed of at a recycling facility.

As the person responsible for the equipment, it is your responsibility to obtain information on approved collection stations.

For further information contact the nearest ESAB dealer.

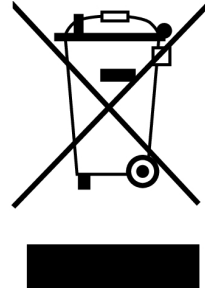

**ESAB has an assortment of welding accessories and personal protection equipment for purchase. For ordering information contact your local ESAB dealer or visit us on our website.**

## 2 INTRODUCTION

This Instruction manual describes the use and maintenance of the conventional roller beds, referred to as roller beds in this document. Actions that must be carried out by the manufacturer are not included in this manual.

This manual is part of the roller beds. Keep a copy of the manual with the roller beds and the original in a safe place. If the roller beds are sold, supply the manual with it.

The pictures and diagrams used in this manual are for illustrative purposes only to help explain instructions in the text. The equipment supplied may differ slightly.

### 2.1 Equipment

The roller bed drive is supplied with:

- Drive units
- Mounted control cabinet
- Wireless remote - control pendant
- Base frame
- Instruction manual

The roller bed idler is supplied with:

- Idler units
- Base frame

### 2.2 Purpose and function of roller beds

The roller beds are designed to aid the welding of cylindrical vessels.

By using the independent drive and idler units, vessels of varying lengths can be placed on the roller beds supported on the roller bed wheels. The wheels can be adjusted on the base frame to accommodate different vessel diameters.

### 2.3 Terminology used in this manual

Drive unit	Roller bed section with powered wheels.
Idler unit	Roller bed section with freewheeling wheels.
Roller bed set	A set consists of one drive unit and one or more idler units.
Base frame	The frame the drive or idler wheels are mounted on. These are pre-drilled so that the wheel stands can be positioned for different vessel diameters.
Wheel stand	The stand which houses the roller bed wheels. This is bolted down to the baseframe.
Control panel	Electrical control box mounted on the drive unit.
Wireless remote - control pendant	A wireless operator hand control pendant.
Receiver	The receiver that communicates with the wireless remote-control pendant.
Vessel	Any component or device that is handled on the roller bed set.

## 3 TECHNICAL DATA

### 3.1 ECD/ECI 7.5

#### 3.1.1 Drive unit ECD 7.5

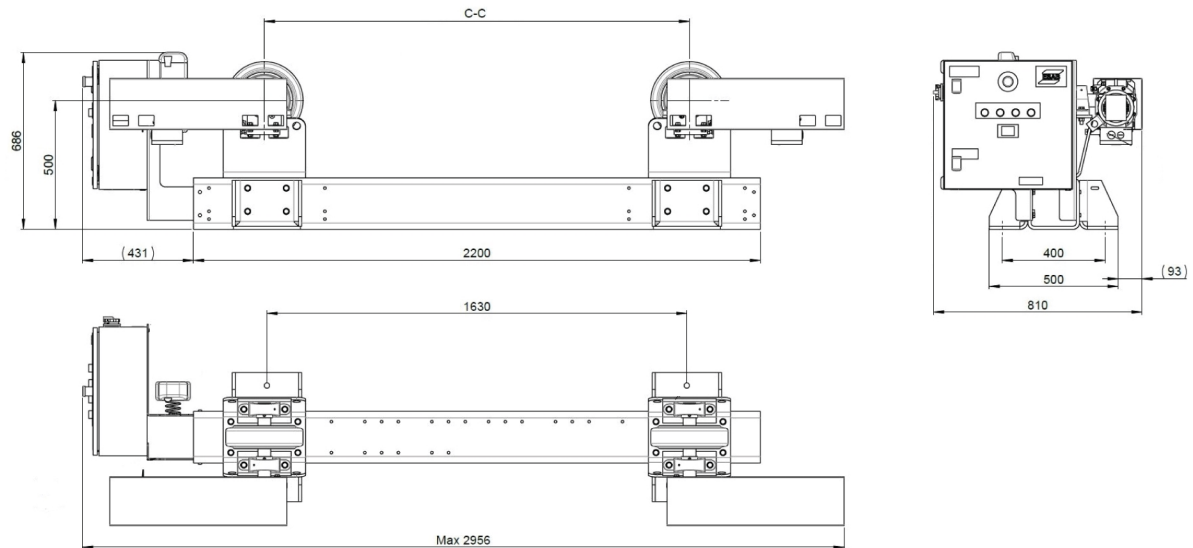

<b>ECD 7.5</b>	
Max loading capacity	3750 kg (8269 lb)
Turning capacity	11250 kg (24806 lb)
Turning drive motor	2×0.25 kW
Turning speed	150–1500 mm/min (5.91–59.05 in./min)
Workpiece diameter minimum	Ø400 mm (15.75 in.) at 60° included angle
Workpiece diameter maximum	Ø4000 mm (157.48 in.) at 45° included angle
Mains supply	380–440 V, 3 phase, 50 Hz
Mains fuse	16 A
Roller type	Polyurethane (90 °C / 92 °A Shore)
Roller width / diameter	90 / 300 mm (3.54 / 11.81 in.)
Dimensions (L × W × H)	2956 × 810 × 686 mm (116.4 × 31.89 × 27.01 in.)
C-C	350, 480, 610, 870, 1130, 1390, 1650 mm (13.78, 18.90, 24.02, 34.25, 44.49, 54.72, 64.96 in.)
Weight	450 kg (992 lb)
Wireless remote - control pendant	Wireless
Control voltage	24 V
Operation temperature	-15 to +40 °C (53.5 to 104 °F)
<b>PEK settings, ECD 7.5</b>	
Gear 1 N1:N2	100:1

### 3 TECHNICAL DATA

Gear 2 N1:N2	10:1
Gear 3 N1:N2	1:1
Wheel diameter	400 mm (15.75 in.)
High manual speed	200 cm/min (78.75 in./min)
Frequency ratio N1	50 Hz
Frequency ratio N2	50 Hz
Max motor rpm	1592

#### 3.1.2 Idler unit ECI 7.5

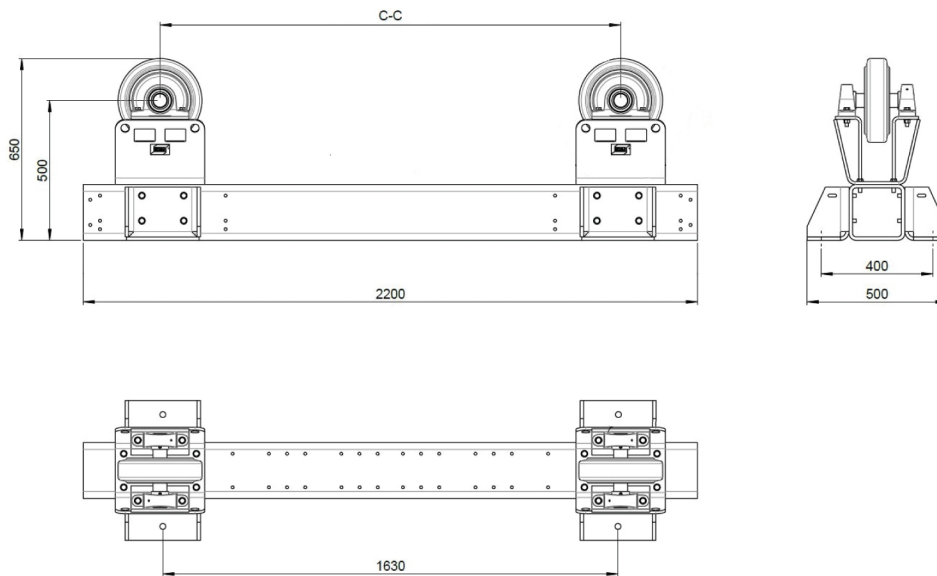

<b>ECI 7.5</b>	
Max loading capacity	3750 kg (8269 lb)
Roller type	Polyurethane (90 °C / 92 °A Shore)
Roller width / diameter	90 / 300 mm (3.54 / 11.81 in.)
Dimensions (L × W × H)	2200 × 500 × 650 mm (86.61 × 19.69 × 25.59 in.)
C - C	350, 480, 610, 870, 1130, 1390, 1650 mm (13.78, 18.90, 24.02, 34.25, 44.49, 54.72, 64.96 in.)
Weight	300 kg (661 lb)

## 3.2 ECD/ECI 15

### 3.2.1 Drive unit ECD 15

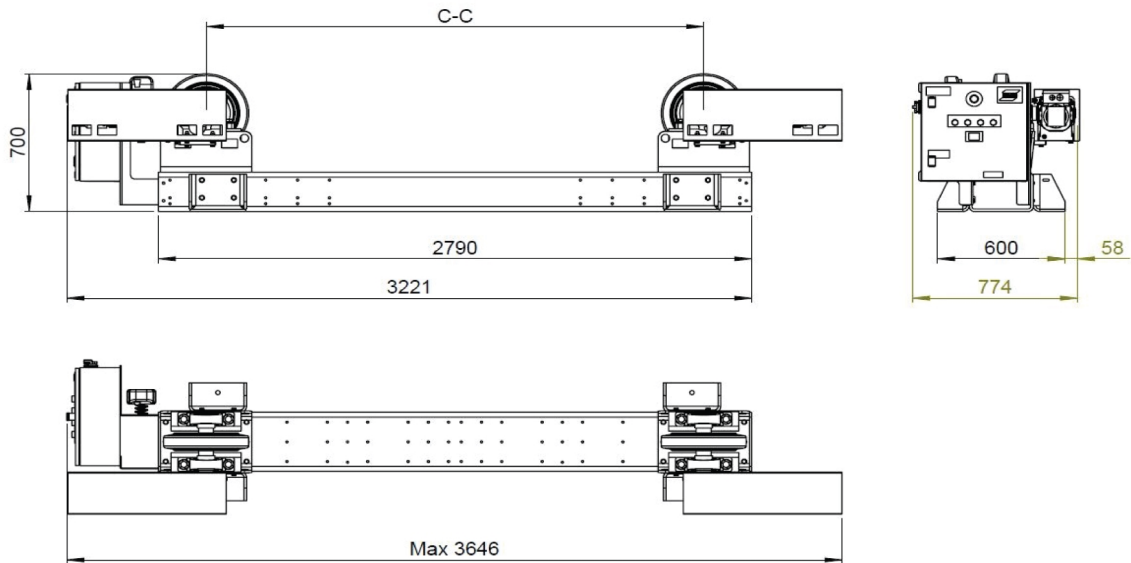

<b>ECD 15</b>	
Max loading capacity	7500 kg (16535 lb)
Turning capacity	22500 kg (49604 lb)
Turning drive motor	2×0.18 kW
Turning speed	200–2000 mm/min (5.51-78.74 in./min)
Workpiece diameter minimum	Ø480 mm (18.90 in.) at 60° included angle
Workpiece diameter maximum	Ø5700 mm (224.41 in.) at 45° included angle
Mains supply	380–440 V, 3 phase, 50 Hz
Mains fuse	16 A
Roller type	Polyurethane (90 °C / 92 °A Shore)
Roller width / diameter	90 / 400 mm (3.54 in. / 15.74 in.)
Dimensions (L × W × H)	3647 × 774 × 700 mm (143.58 × 30.47 × 27.55 in.)
C-C	440, 630, 820, 1200, 1580, 1960, 2340 mm (17.32, 24.80, 32.28, 47.24, 62.20, 77.16, 92.12 in.)
Weight	650 kg (1433 lb)
Wireless remote - control pendant	Wireless
Control voltage	24 V
Operation temperature	-15 to +40 °C (53.5 to 104 °F)

<b>PEK settings, ECD-15</b>	
Gear 1 N1:N2	100:1
Gear 2 N1:N2	10:1
Gear 3 N1:N2	1:1
Wheel diameter	400 mm (15.75 in.)



### 3 TECHNICAL DATA

High manual speed	200 cm/min (78.75 in./min)
Frequency ratio N1	50 Hz
Frequency ratio N2	50 Hz
Max motor rpm	1592

#### 3.2.2 Idler unit ECI 15

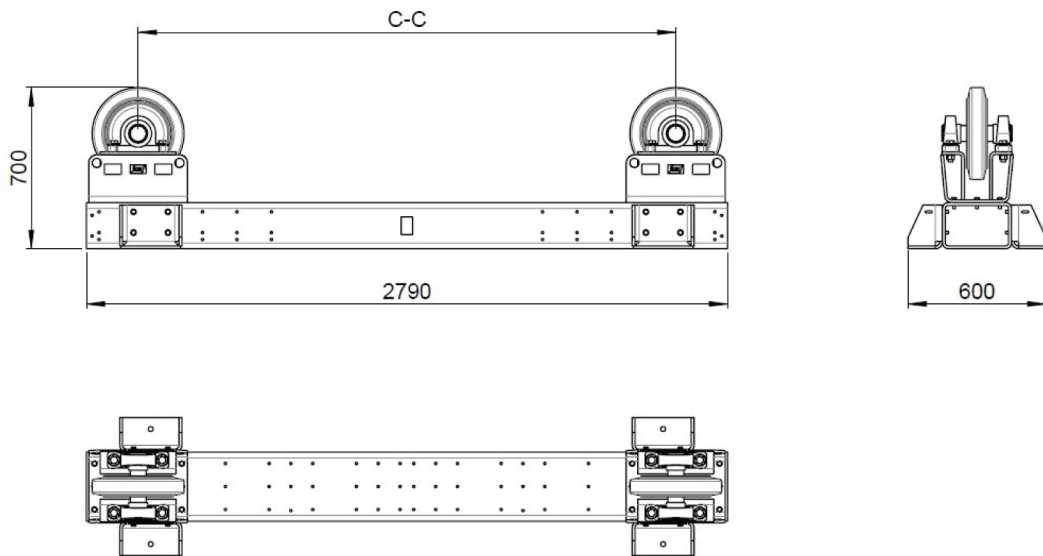

<b>ECI 15</b>	
Max loading capacity	7500 kg (16535 lb)
Roller type	Polyurethane (90 °C / 92 °A Shore)
Roller width / diameter	90 mm (3.54 in.) / 400 mm (15.74 in.)
Dimensions (L × W × H)	2790 × 600 × 700 mm (109.84 × 23.62 × 27.55 in.)
C - C	440, 630, 820, 1200, 1580, 1960, 2340 mm (17.32, 24.80, 32.28, 47.24, 62.20, 77.16, 92.12 in.)
Weight	500 kg (1102 lb)

## 3.3 ECD/ECI 30

### 3.3.1 Drive unit ECD 30

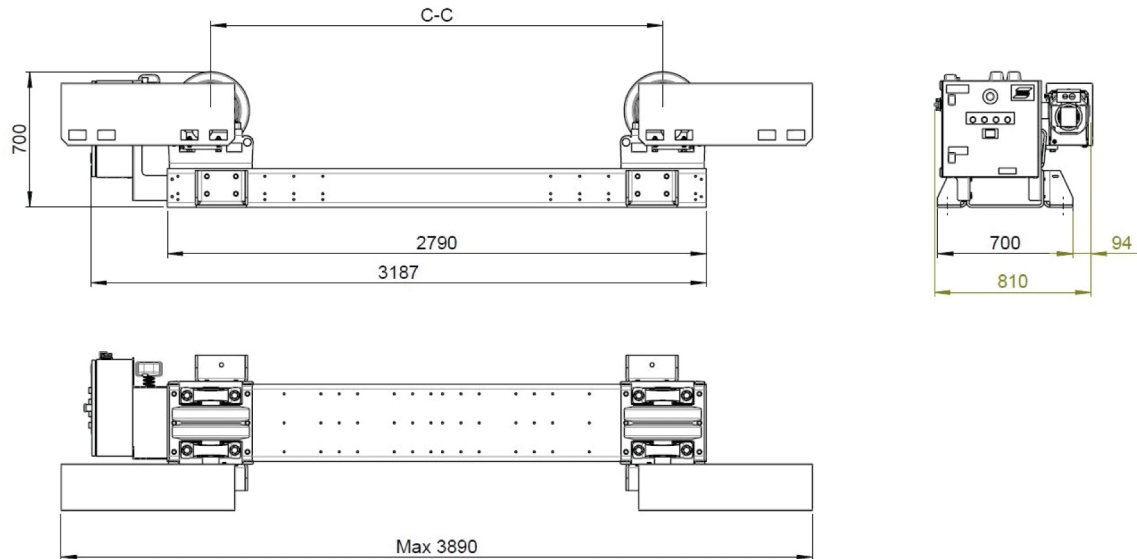

<b>ECD 30</b>	
Max loading capacity	15000 kg (33069 lb)
Turning capacity	45000 kg (99208 lb)
Turning drive motor	2×0.37 kW
Turning speed	200–2000 mm/min (5.51-78.74 in./min)
Workpiece diameter minimum	Ø480 mm (18.90 in.) at 60° included angle
Workpiece diameter maximum	Ø5700 mm (224.41 in.) at 45° included angle
Mains supply	380–440 V, 3 phase, 50 Hz
Mains fuse	16 A
Roller type	Polyurethane (90 °C / 92 °A Shore)
Roller width / diameter	2×90 mm / 400 mm (2×3.54 / 15.74 in.)
Dimensions (L × W × H)	3890 × 810 × 700 mm (153.15 × 31.88 × 27.55 in.)
C-C	440, 630, 820, 1200, 1580, 1960, 2340 mm (17.32, 24.80, 32.28, 47.24, 62.20, 77.16, 92.12 in.)
Weight	850 kg (1874 lb)
Wireless remote - control pendant	Wireless
Control voltage	24 V
Operation temperature	-15 to +40 °C (53.5 to 104 °F)

<b>PEK settings, ECD 30</b>	
Gear 1 N1:N2	100:1
Gear 2 N1:N2	10:1
Gear 3 N1:N2	1:1
Wheel diameter	400 mm (15.75 in.)

### 3 TECHNICAL DATA

High manual speed	200 cm/min (78.75 in./min)
Frequency ratio N1	50 Hz
Frequency ratio N2	50 Hz
Max motor rpm	1592

#### 3.3.2 Idler unit ECI 30

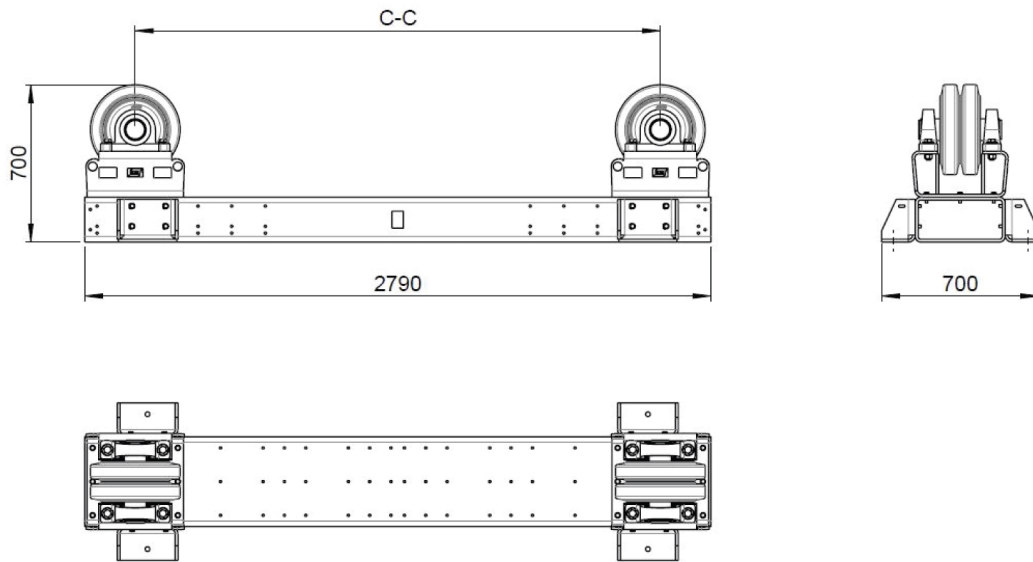

<b>ECI 30</b>	
Max loading capacity	15000 kg (33069 lb)
Roller type	Polyurethane (90 °C / 92 °A Shore)
Roller width / diameter	2×90 mm / 400 mm (2×3.54 / 15.74 in.)
Dimensions (L × W × H)	2790 × 700 × 700 mm (109.84 × 27.55 × 27.55 in.)
C-C	440, 630, 820, 1200, 1580, 1960, 2340 mm (17.32, 24.80, 32.28, 47.24, 62.20, 77.16, 92.12 in.)
Weight	650 kg (1433 lb)

## 3.4 ECD/ECI 60

### 3.4.1 Drive unit ECD 60

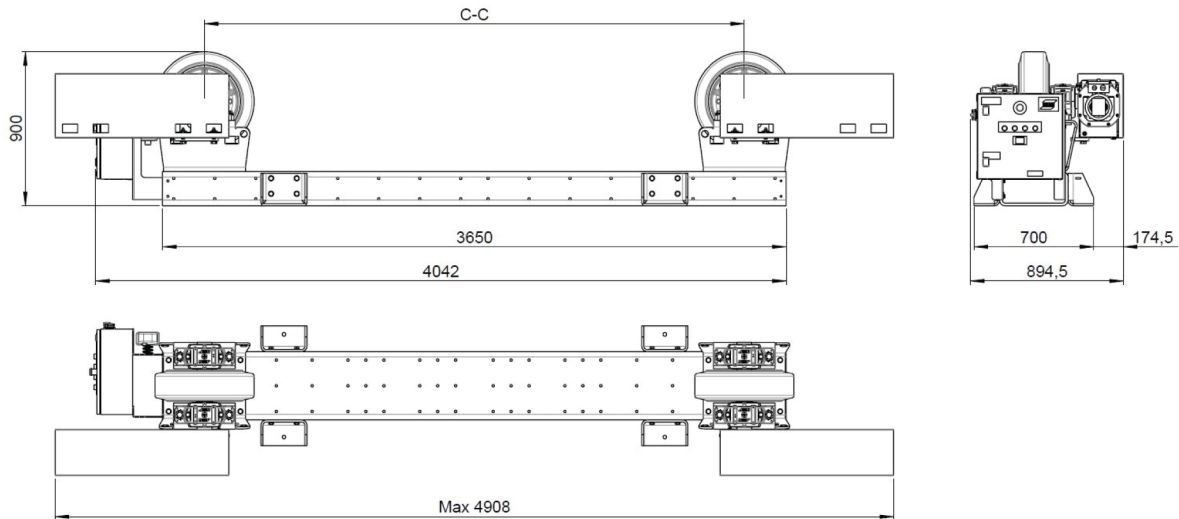

<b>ECD 60</b>	
Max loading capacity	30000 kg (66139 lb)
Turning capacity	90000 kg (198416 lb)
Turning drive motor	2×0.75 kW
Turning speed	200–2000 mm/min (5.51-78.74 in./min)
Workpiece diameter minimum	Ø700 mm (27.56 in.) at 60° included angle
Workpiece diameter maximum	Ø7600 mm (299.21 in.) at 45° included angle
Mains supply	380–440 V, 3 phase, 50 Hz
Mains fuse	16 A
Roller type	Polyurethane (90 °C / 92 °A Shore)
Roller width / diameter	180 / 580 mm (7.09 / 22.8 in.)
Dimensions (L × W × H)	4908 × 896 × 900 mm (193.23 × 35.28 × 35.43 in.)
C-C	640, 850, 1060, 1480, 1900, 2320, 2740, 3160 mm (25.19, 33.46, 41.73, 58.26, 74.80, 91.33, 107.87, 124.40 in.)
Weight	1300 kg (2866 lb)
Wireless remote - control pendant	Wireless
Control voltage	24 V
Operation temperature	-15 to +40 °C (53.5 to 104 °F)

<b>PEK settings, ECD 60</b>	
Gear 1 N1:N2	100:1
Gear 2 N1:N2	10:1
Gear 3 N1:N2	1:1
Wheel diameter	580 mm (22.83 in.)

High manual speed	200 cm/min (78.75 in./min)
Frequency ratio N1	50 Hz
Frequency ratio N2	50 Hz
Max motor rpm	1098

### 3.4.2 Idler unit ECI 60

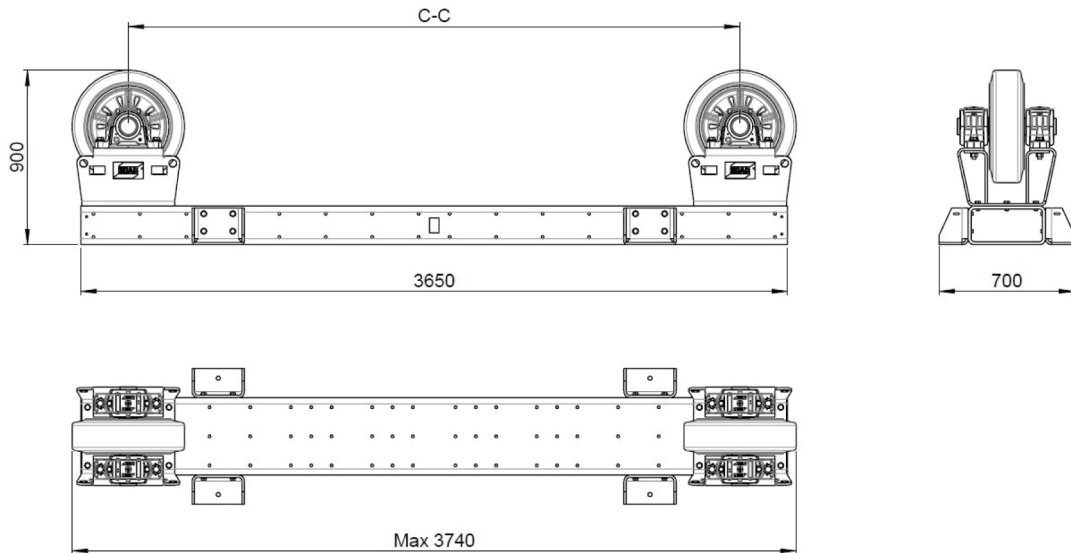

<b>ECI 60</b>	
Max loading capacity	30000 kg (66139 lb)
Roller type	Polyurethane (90 °C / 92 °A Shore)
Roller width / diameter	180 / 580 mm (7.08 / 22.83 in.)
Dimensions (L × W × H)	3740 × 700 × 900 mm (147.24 × 27.55 × 35.43 in.)
C-C	640, 850, 1060, 1480, 1900, 2320, 2740, 3160 mm (25.19, 33.46, 41.73, 58.26, 74.80, 91.33, 107.87, 124.40 in.)
Weight	1000 kg (2205 lb)

## 3.5 ECD/ECI 90

### 3.5.1 Drive unit ECD 90

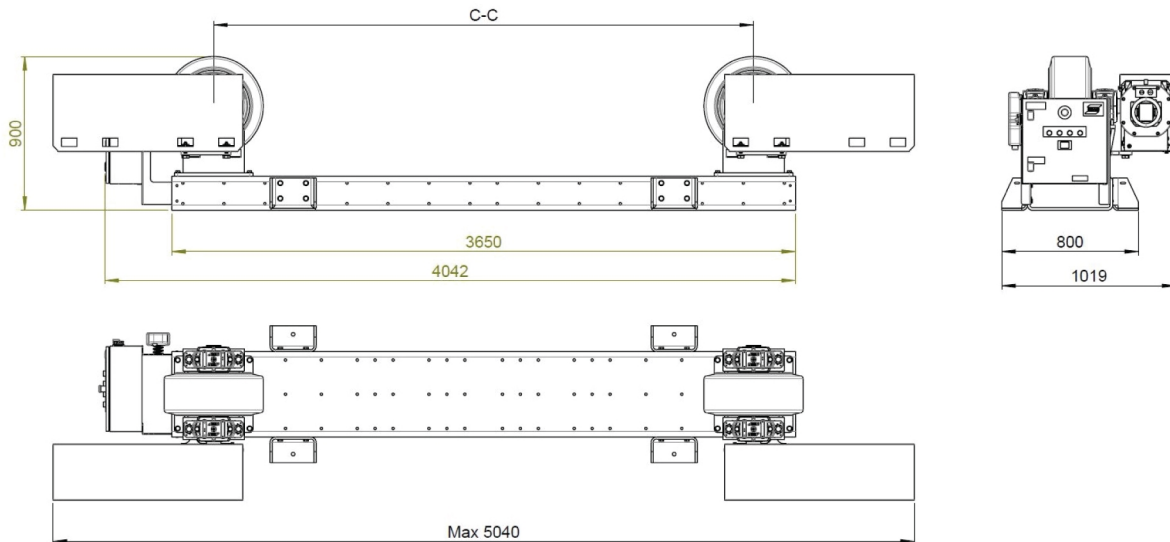

<b>ECD 90</b>	
Max loading capacity	45000 kg (66139 lb)
Turning capacity	135000 kg (297624 lb)
Turning drive motor	2×1.0 kW
Turning speed	200–2000 mm/min (5.51-78.74 in./min)
Workpiece diameter minimum	Ø700 mm (27.56 in.) at 60° included angle
Workpiece diameter maximum	Ø7600 mm (299.21 in.) at 45° included angle
Mains supply	380–440 V, 3 phase, 50 Hz
Mains fuse	16 A
Roller type	Polyurethane (90 °C / 92 °A Shore)
Roller width / diameter	250 / 580 mm (9.84 / 22.83 in.)
Dimensions (L × W × H)	5040 × 1019 × 900 mm (198.43 × 40.12 × 35.43 in.)
C-C	640, 850, 1060, 1480, 1900, 2320, 2740, 3160 mm (25.19, 33.46, 41.73, 58.26, 74.80, 91.33, 107.87, 124.40 in.)
Weight	1700 kg (3748 lb)
Wireless remote - control pendant	Wireless
Control voltage	24 V
Operation temperature	-15 to +40 °C (53.5 to 104 °F)

<b>PEK settings, ECD 90</b>	
Gear 1 N1:N2	100:1
Gear 2 N1:N2	10:1
Gear 3 N1:N2	1:1
Wheel diameter	580 mm (22.83 in.)

### 3 TECHNICAL DATA

High manual speed	200 cm/min (78.75 in./min)
Frequency ratio N1	50 Hz
Frequency ratio N2	50 Hz
Max motor rpm	1098

#### 3.5.2 Idler unit ECI 90

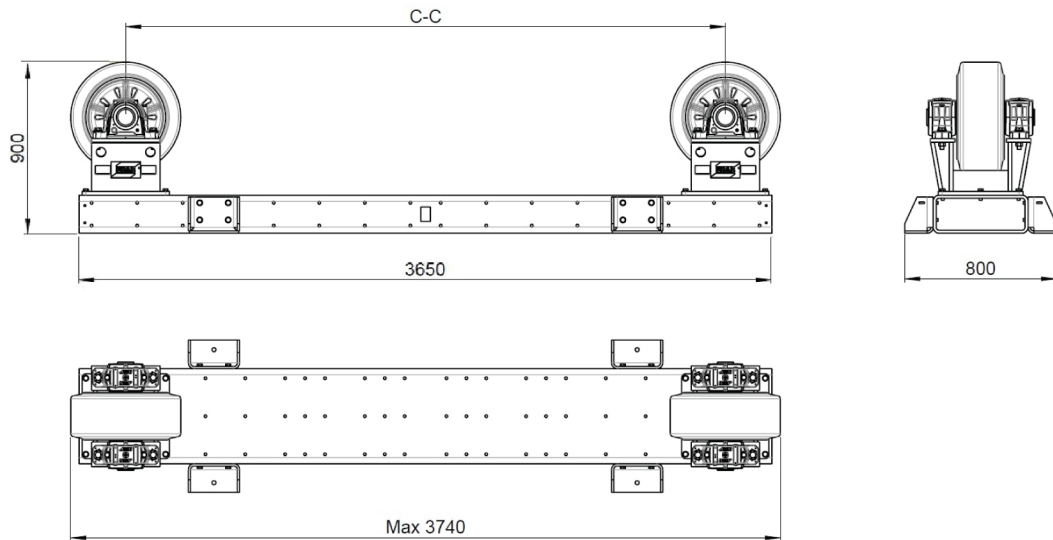

<b>ECI 90</b>	
Max loading capacity	45000 kg (99208 lb)
Roller type	Polyurethane (90 °C / 92 °A Shore)
Roller width / diameter	250 / 580 mm (9.84 / 22.83 in.)
Dimensions (L × W × H)	3740 × 800 × 900 mm (147.24 × 31.49 × 35.43 in.)
C-C	640, 850, 1060, 1480, 1900, 2320, 2740, 3160 mm (25.19, 33.46, 41.73, 58.26, 74.80, 91.33, 107.87, 124.40 in.)
Weight	1250 kg (2756 lb)

## 3.6 ECD/ECI 120

### 3.6.1 Drive unit ECD 120

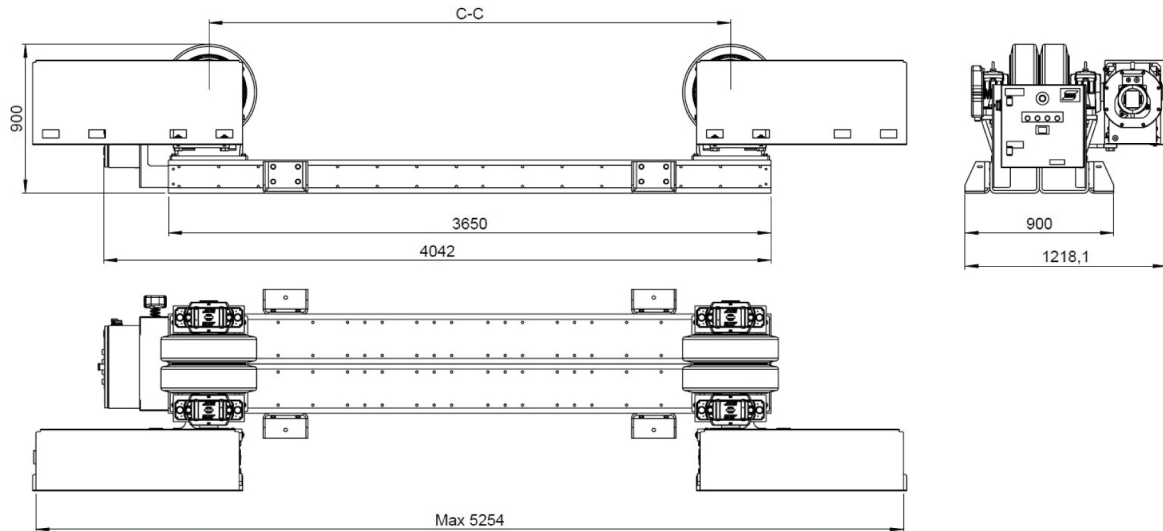

<b>ECD 120</b>	
Max loading capacity	60000 kg (132277 lb)
Turning capacity	180000 kg (396832 lb)
Turning drive motor	2×1.5 kW
Turning speed	200–2000 mm/min (7.87-78.74 in./min)
Workpiece diameter minimum	Ø700 mm (27.56 in.) at 60° included angle
Workpiece diameter maximum	Ø7600 mm (299-21 in.) at 45° included angle
Mains supply	380–440 V, 3 phase, 50 Hz
Mains fuse	16 A
Roller type	Polyurethane (90 °C / 92 °A Shore)
Roller width / diameter	2×180 mm / 580 mm (2×7.08 / 22.83 in.)
Dimensions (L × W × H)	5254 × 1218 × 900 mm (206.85 × 47.96 × 35.43 in.)
C-C	640, 850, 1060, 1480, 1900, 2320, 2740, 3160 mm (25.19, 33.46, 41.73, 58.26, 74.80, 91.33, 107.87, 124.40 in.)
Weight	2500 kg (5512 lb)
Wireless remote - control pendant	Wireless
Control voltage	24 V
Operation temperature	-15 to +40 °C (53.5 to 104 °F)

<b>PEK settings, ECD 120</b>	
Gear 1 N1:N2	100:1
Gear 2 N1:N2	10:1
Gear 3 N1:N2	1:1
Wheel diameter	580 mm (22.83 in.)



### 3 TECHNICAL DATA

High manual speed	200 cm/min (78.75 in./min)
Frequency ratio N1	50 Hz
Frequency ratio N2	50 Hz
Max motor rpm	1098

#### 3.6.2 Idler unit ECI 120

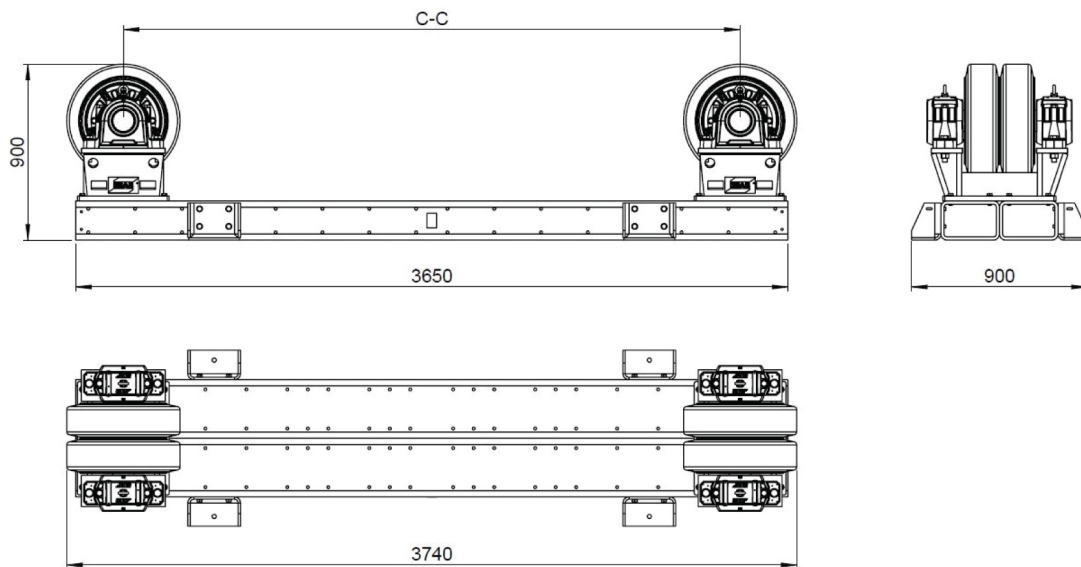

ECI 120	
Max loading capacity	60000 kg (132277 lb)
Roller type	Polyurethane (90 °C / 92 °A Shore)
Roller width / diameter	2×180 / 580 mm (2×7.08 / 22.83 in.)
Dimensions (L × W × H)	3740 × 900 × 900 mm (147.24 × 35.43 × 35.43 in.)
C-C	640, 850, 1060, 1480, 1900, 2320, 2740, 3160 mm (25.19, 33.46, 41.73, 58.26, 74.80, 91.33, 107.87, 124.40 in.)
Weight	1850 kg (4079 lb)

## 4 INSTALLATION

### 4.1 Location



#### WARNING!

Always ensure that there is sufficient space around the roller beds.

Make sure to have suitable access and enough space around the roller beds, including the vessel when loaded. Position it to allow unhindered loading and unloading of vessels onto the roller beds by overhead crane or other lifting devices

### 4.2 Lifting instructions

Use correctly rated overhead cranes or forklift trucks to move the roller beds.

#### Lifting by crane

The roller beds can be lifted by using the lifting points on the roller bed wheel stands. Use one lifting point on each side of the wheel stand, 4 lifting points in all. The recommended angle between the chain and the lifting points on the roller beds is 60°.

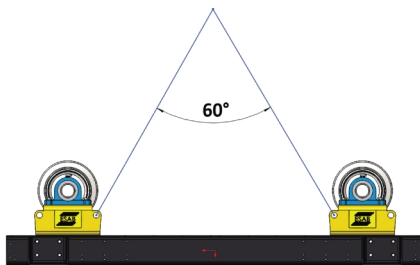

Place the roller beds on a smooth, level, hard floor that is capable of taking the weight of the roller bed and vessel, over the contact area of the roller bed with the floor.

The distances between the base frames should match the vessel dimensions. If the vessel is perfectly symmetrical and one drive with one idler is used, place the drive unit and the idler unit on one-third of the way along the vessel's length to ensure that each section carries an equal load.

If one end of the vessel is heavier, move the drive or idler section closer to this end to balance the loading on each section.



#### CAUTION!

Balance the loading equally between the drive and idler sections. Failure to do so can result in overloading one of the sections, which will cause the wheels slipping when trying to rotate the vessel. It can also result in back-driving, where the vessel can continue to rotate after stopping the roller beds. This must be rectified by correctly positioning the drive and idler section, failure to do so will cause damage to the equipment.



#### WARNING!

When a direction button (forward or reverse) is pressed, the roller beds begin to turn the vessel.

## 4.3 Adjusting the wheel stands

The positions of the two wheel stands on the base frame must be adjusted to load vessels of different diameters.

1. Unbolt the wheel stand from the base frame.
2. Use an overhead crane to lift the wheel stand using the lifting points.
3. Move the wheel stand to the required position for the diameter of the vessel.
4. Bolt the wheel stands back onto the base frame using all the bolts, and tighten to the correct torque i.e. M12 (8.8) 81 Nm and M16 (8.8) 197 Nm.
5. See tables and the picture below for correct distances between the two wheels stands.

**Suitable centre to centre distance (C -C) in relation to workpiece diameter**

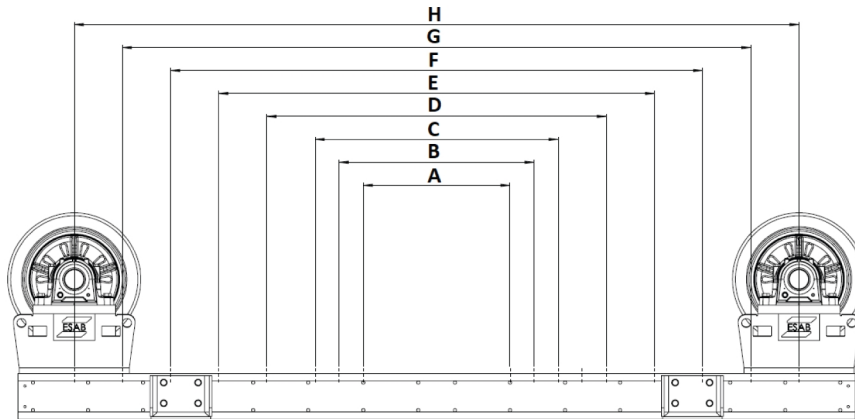

<b>ECD 7.5, ECI 7.5</b>			
<b>Wheel stand position</b>	<b>C- C (mm)</b>	<b>Min object Ø (mm)</b>	<b>Max object Ø (mm)</b>
A	350	400	610
B	480	610	950
C	610	920	1290
D	870	1280	1970
E	1130	1960	2650
F	1390	2480	3330
G	1650	3000	4000

<b>ECD 15, ECI 15, ECD 30, ECI 30</b>			
<b>Wheel stand position</b>	<b>C- C (mm)</b>	<b>Min object Ø (mm)</b>	<b>Max object Ø (mm)</b>
A	440	480	750
B	630	750	1240
C	820	1240	1740
D	1200	1740	2730
E	1580	2730	3700
F	1960	3600	4700
G	2340	4300	5700

ECD 60, ECI 60, ECD 90, ECI 90, ECI 120, ECI 120			
Wheel stand position	C- C (mm)	Min object Ø (mm)	Max object Ø (mm)
A	640	700	1090
B	850	1090	1640
C	1060	1540	2180
D	1480	2180	3280
E	1900	3220	4300
F	2320	4100	5400
G	2740	4900	6500
H	3160	5800	7600

**NOTE!**

Adjust the wheel stands so that the axis of rotation of the vessel is on the centre line of the drive and idler frames.

## 4.4 Adjusting the included angle

The included angle ( $\alpha$ ) is the angle between two lines from the centre of the rotation axis of the vessel to the centre of each wheel on the drive or idler section. As the angle increases, so do the resulting load on each wheel, and consequently, the load on the bearings. Also, by increasing the angle, more torque, therefore more power is required to rotate the vessel.

The distance between the wheel stands, on both the drive unit and the idler units depends on the diameter of the vessel. To achieve a safe and smooth operation of the roller beds the recommendation is to keep the included angle ( $\alpha$ ) between  $45^\circ$  and  $70^\circ$ .

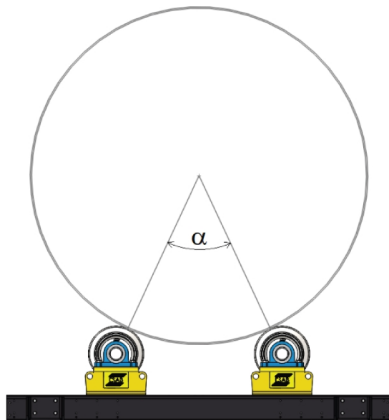

## 4.5 Installation procedure

Follow this installation procedure before the first use, after maintenance or repair work, or after a storage period of the roller beds.

The roller beds are fully tested functionally before dispatching from the factory.

It is recommended to check the operation of all controls before the roller beds are taken into production.

Installation procedure:

- Check that all moving parts, for example, the wheels, can move freely.
- Check the oil level in the gearbox, see section "Gearbox lubrication".
- Check the integrity of all cables, mains, and motors, make sure there are no cuts, etc.
- Check that all wireless remote - control pendant controls operate correctly.
- Check that the emergency stop on both wireless remote - control pendants is functional and locks all other controls so the roller beds cannot restart, then reset on the control panel.
- Check that the emergency stop on the control panel works and locks all other controls so the roller beds cannot restart, then reset on the control panel.
- Check that the steel framework is not damaged.

## 4.6 PEK setup



**NOTE!**

The following description requires basic knowledge of ESAB welding process PEK control unit . For more information about PEK control unit , refer to the PEK control unit instruction manual.

Follow these instructions to set up the PEK control unit when a roller bed is connected to an ESAB CaB.

- 1) To configure a connected roller bed in PEK control unit, select *MAIN MENU » MACHINE CONFIGURATION » CONFIGURATION*.
- 2) Select *PRODUCT CODE » FREE 3 AXIS*.

<i>MACHINE CONFIGURATION</i>		
<i>PRODUCT CODE</i>	<i>FREE 3 AXIS</i>	
<i>WIRE FEED AXIS ▶</i>		
<i>TRAVEL AXIS ▶</i>		
<i>EXTERNAL AXIS ▶</i>		
<i>TANDEM ▶</i>		
<i>ICE WIRE FEED ▶</i>	<i>OFF</i>	
<i>STEP FUNCTION ▶</i>	<i>OFF</i>	

- 3) Select *EXTERNAL AXIS » ROLLER BED*. See PEK settings in chapter "TECHNICAL DATA" for referred tables. Enter values for:
  - GEAR 1 - values from the table for the specific roller bed size.
  - GEAR 2 - values from the table for the specific roller bed size.
  - GEAR 3 - not used for roller beds, default value is 1:1.
- 4) Enter the rest of the *EXTERNAL AXIS* values. See PEK settings in chapter "TECHNICAL DATA" for referred tables.
  - *WHEEL DIAMETER* - enter the value from the table for the specific roller bed size.
  - Parameters not used: *SPEED WHEEL*, *ENCODER-PULSES* and *ENCODER INPUTS*.
  - *HIGH MANUAL SPEED* - enter the maximum turning speed value from the table for the specific roller bed size.



**NOTE!**

The units used in the table and in PEK may differ.

- *FREQUENCY RATION N1* - enter the inverter frequency setting value from the table for the specific roller bed size.
- *FREQUENCY RATION N2* - default value is 50 Hz.

#### 4 INSTALLATION

---

- *MAX MOTOR RPM* - enter the value from the table for the specific roller bed size, motor output at 50 Hz.
- *WELD DIAMETER* - enter the diameter (mm) of the work piece where the weld will be carried out. If welding on the surface, this value will be equal to the roll diameter.
- *ROLL DIAMETER* - enter the outer diameter (mm) of the actual work piece.

## 4.7 Roller bed configurations

The figure below shows different setup options for the CaB and roller bed. For further details see section "WIRING DIAGRAM". For interface cable and synchronization cable see section "ACCESSORIES".

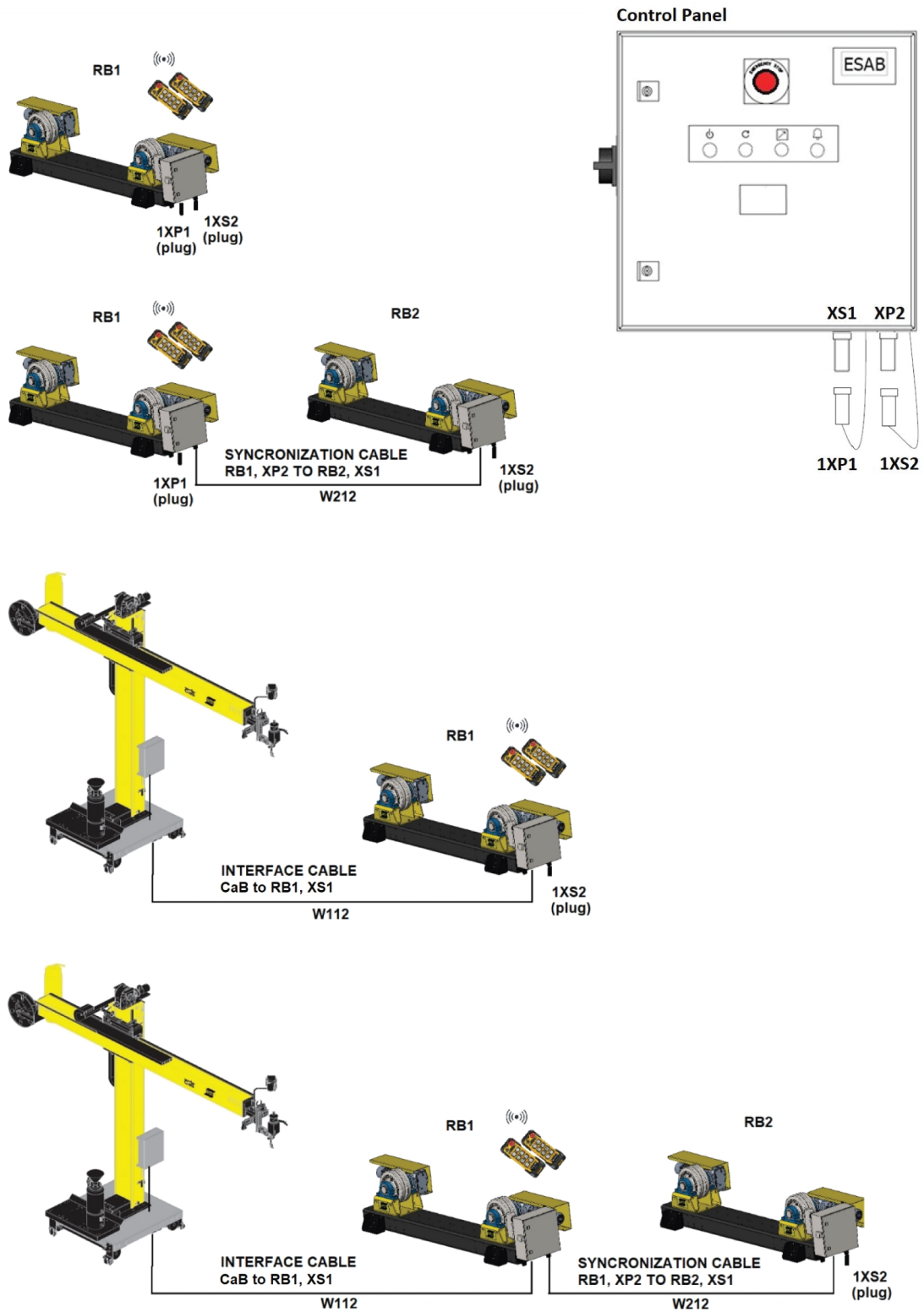

## 5 OPERATION

### 5.1 Roller bed details

The roller bed set usually consists of one drive unit and one, two or, three idler units.

The idler unit consists of a base frame with two wheel stands bolted onto the top of it. Holes are drilled through the top of the base frame for the wheel stands to be positioned at different distances to suit the vessel diameter.

The drive unit consists of two-wheel stands that can be positioned to suit the vessel diameter. Both wheel stands are motorized. The wheel is turned by a gear motor mounted straight onto the drive shaft.

Inside the control panel is an inverter that controls the motors.

The roller bed is manually controlled via a wireless remote - control pendant. It can also be connected to a welding manipulator, for example, ESAB CaB, and then controlled by the CaB controller.

### 5.2 Control panel

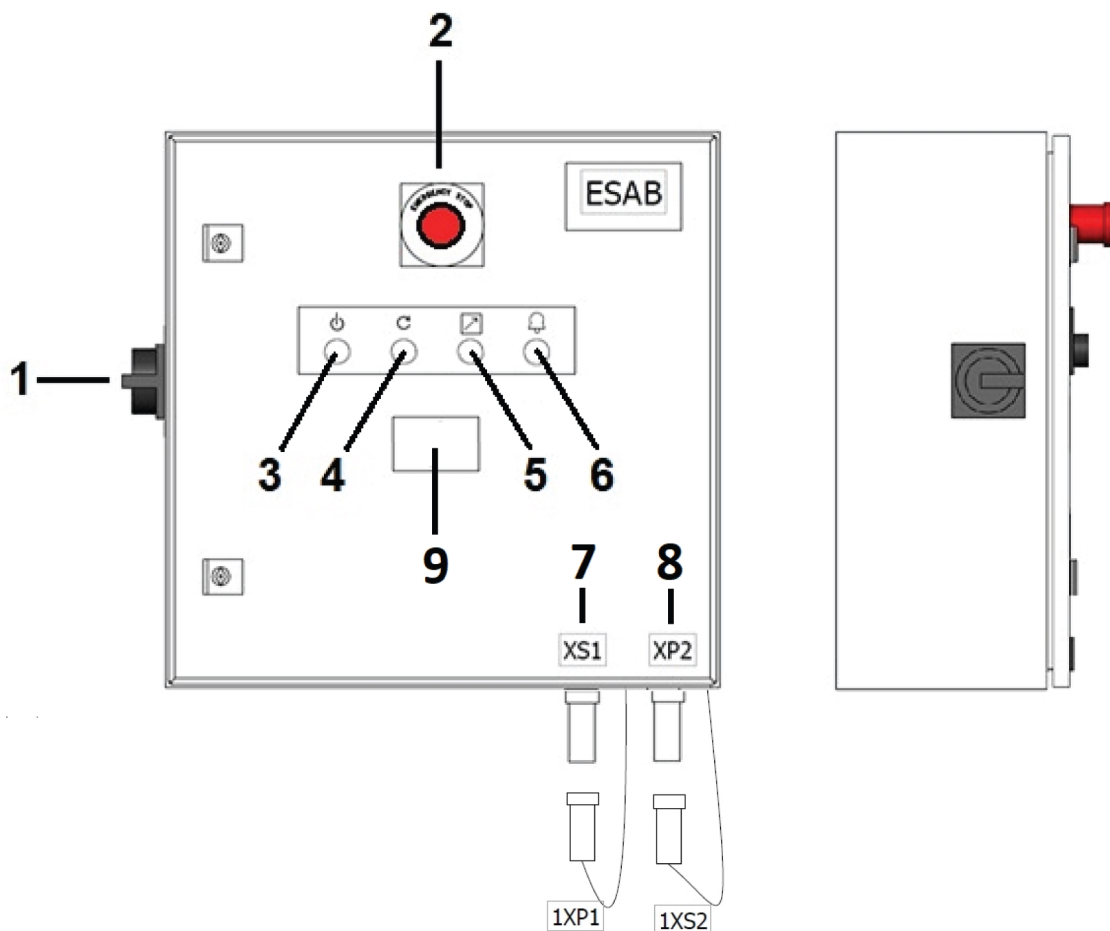

- |  |  |
|--|--|
| 1. Mains switch (A1)                     | 6. Alarm lamp/pushbutton (A33)                 |
| 2. Emergency stop button (A30)           | 7. Connector to external control (XS1)         |
| 3. Mains ON lamp (A32)                   | 8. Connector to the next roller bed unit (XP2) |
| 4. Emergency stop reset pushbutton (A31) | 9. Digital display (A35) (optional)            |
| 5. White lamp (A34)                      |  |



**Control panel**

1. Mains switch (A1).
2. Emergency stop button (A30). Pressing causes loss of function. The button must be released before reset is possible.
3. Mains ON lamp (A32). Illuminates (green) once power has been turned on and the control system has started up. (Mains switch (1) is turned to ON position). This pushbutton, in combination with (A33), is also used for calibration and reset of a second roller bed (RB2) connected to the primary roller bed (RB1).
4. E-stop reset button (A31). Illuminates (blue) when any of the emergency stop pushbuttons are activated and/or not reset. It flashes when the e-stop pushbuttons are de-activated again and will go off when the buttons are pushed (E-stop reset).
5. White lamp (A34). Illuminates after requested control mode has been chosen, either local (illuminates constantly) or controlled from an external device (flashes), for example, ESAB CaB. Press this pushbutton to activate local control when the roller bed is used as a standalone unit. Press again to deactivate it. When the roller bed is connected to and controlled from an ESAB CaB i.e., digital output from the CaB is set to high, this lamp flashes until the signal is set to low again.
6. Alarm lamp / pushbutton (A33). Illuminates constantly (red) when any kind of fault has occurred. Must be manually reset after the fault has been detected and fixed. It flashes if battery power is low on the wireless remote-control pendant and stops flashing when the battery is charged or replaced. This pushbutton, in combination with (A32), is also used for calibration and reset of a second roller bed (RB2) connected to the primary roller bed (RB1).
7. Connector to external control, for example, CaB (XS1). A dummy plug with jumpers (1XP1) must be connected to be able to run the roller bed as a stand-alone unit.
8. Connector to a second roller bed controller i.e., synchronized drives (XP2). A dummy plug with jumpers (1XS2) must be connected to be able to run the roller bed as either a single unit or when it is the last unit in a chain of several connected roller beds.
9. Digital display (A35, when applicable). It shows the peripheral rotation speed of the PU wheels.

### 5.3 Wireless remote - control pendant

The system is delivered with two wireless remote-control pendants with rechargeable batteries, one receiver (mounted behind the control panel), and one inductive charger. The two wireless remote-control pendants are working on the same radio channel and frequency, and therefore only one at a time would be used. Ideally, one is used in the operation while the other is connected to the charger.

**CAUTION!**

Always stop the rotation before changing direction by pressing the same pushbutton that has been pressed last for the requested direction.

**NOTE!**

When one of the direction buttons (forward or reverse) is pressed, the roller beds immediately begin to turn the vessel.

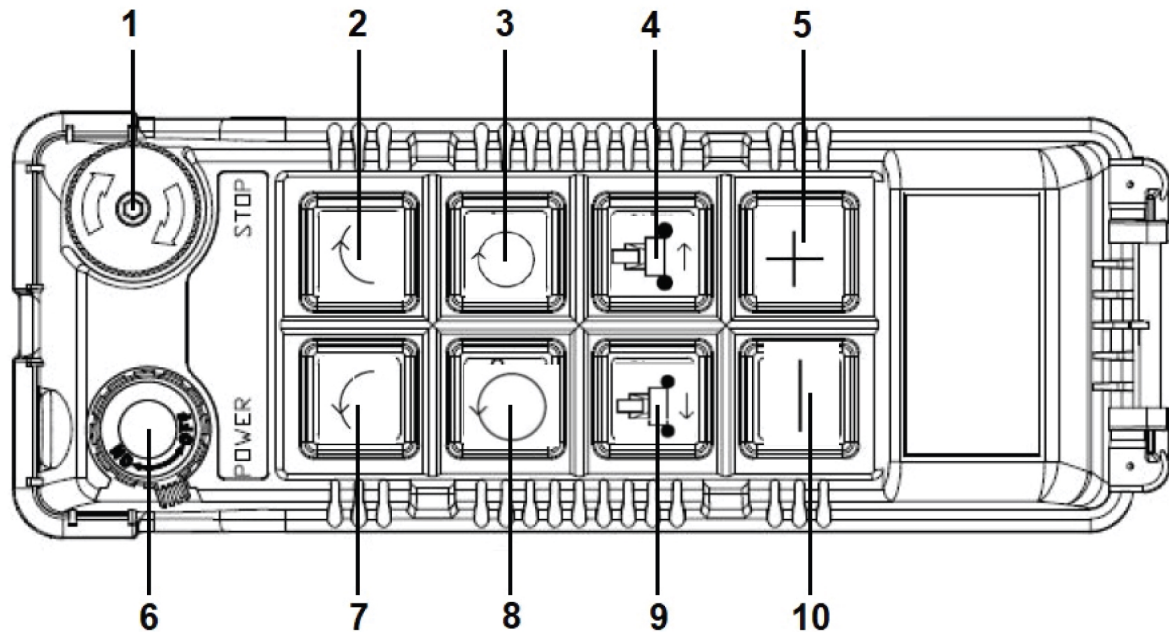

- |   |  |
|---|--|
| 1. Emergency stop button                                      | 6. Main switch, ON/OFF   |
| 2. Incremental rotation clockwise                             | 7. Incremental rotation anti-clockwise                             |
| 3. Continuously rotation clockwise. Toggling function ON/OFF. | 8. Continuously rotation anti-clockwise. Toggling function ON/OFF. |
| 4. Railcar motion direction A                                 | 9. Railcar motion direction B                                      |
| 5. Increasing rotation speed                                  | 10. Decreasing rotation speed                                      |

## 5.4 Switch the mains power on

**WARNING!**

Do not operate the roller beds if there are signs of damage. Always have an authorized ESAB service technician to check and make repairs if necessary.

Before switching on the roller beds, check that:

1. the wheel stands are correctly bolted on the base frame.
2. the wheels are correctly positioned under the vessel.
3. there are no obstructions to prevent rotation of the vessel (if one is loaded).

Visually inspect the wheels, motors, gearboxes, wireless remote - control pendant, control panel and cables for any signs of damage.

**WARNING!**

Make sure that the mains supply matches the electrical voltage shown on the control panel.

**WARNING!**

Ensure that mains cable do not lay on vehicle or forklift traffic lanes and do not cause a tripping hazard.

- 1) Plug in the mains lead to the power supply.
- 2) Switch on the mains power, the mains on lamp (green) on the control panel illuminates.

- 3) Turn on any of the two wireless remote - control pendants.



**WARNING!**

Only **one** remote control unit is to be used while utilising the equipment. The other remote control unit must be turned off and securely stored in a designated location.

- 4) Check that the emergency stop buttons are not pressed in.
- 5) Press the E-stop rest pushbutton.

If running as standalone, press the control mode pushbutton (white lamp).

In case an ESAB CaB is connected to the roller bed, check and verify that settings in the PEK are correct and match the roller bed parameters.

The roller bed is now ready to operate.

## 5.5 Operating the roller beds

- 1) When the roller beds are correctly aligned and the wheel stands are in the correct position, start loading the vessel on the roller beds.

This must be done steadily, to not shock load the roller beds. Shock loading cause damage to the gearmotors.

Ensure that no protuberances on the vessel can strike objects around the roller beds or the floor during rotation.

- 2) Press the desired travel direction (pushbutton 3 or 8). The roller beds now start to turn the vessel.
- 3) To adjust the speed up or down press pushbutton 5 or 10.



**NOTE!**

Test the emergency stop functionality frequently by pressing the e-stop pushbuttons, at least one time a month.

## 5.6 Operation safety

Do not place multiple drive units under one vessel. This is only possible if the optional synchronization cable (W212) has been supplied with the roller beds. In this case, the primary control panel (RB1) controls the secondary drive unit (RB2).

Do not let parts of the vessel, for example, the connection tubes, come into contact with the roller beds, floor, or objects in the vicinity during rotation. This can cause damage to the roller beds and cause the wheels to slip or overload the units.

Make sure to have proper earthing during welding. Lack of proper earthing can cause the electrics on the roller beds to short out.

If the emergency stop button is pressed in, find out the reason for the action before restarting the roller bed.

Make sure that the wheel stands are NOT too far apart.

The roller beds can be overloaded, as more load is put through each wheel if wheel stands are too far apart.

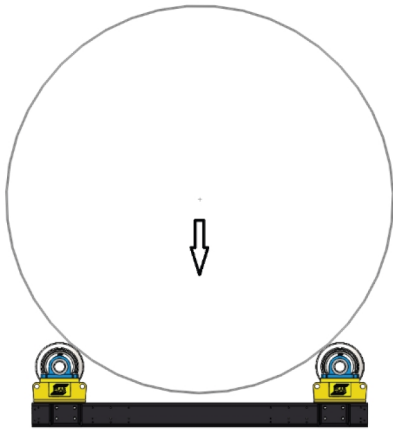

Make sure that the wheel stands are NOT too close together.

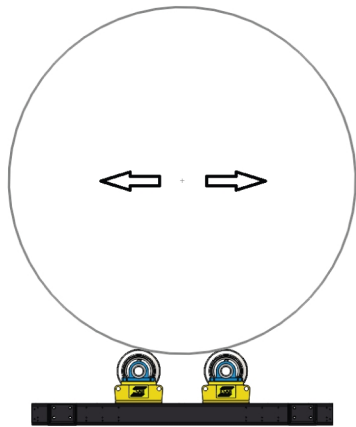

**DANGER!**

Very unsafe position.

Never operate the roller beds at an included angle of less than 45°.

During rotation, the vessel could roll off the roller beds causing serious injury to anyone in the vicinity. This can also happen with an unbalanced load when the centre of gravity of the vessel is offset from the axis of rotation.

See section "Adjusting the wheel stands" for more information. Make sure that the drive and idler units are aligned parallel to each other. Otherwise, the vessel can creep lengthways and fall off the roller beds. This can also cause wear and damage to the roller bed wheels.

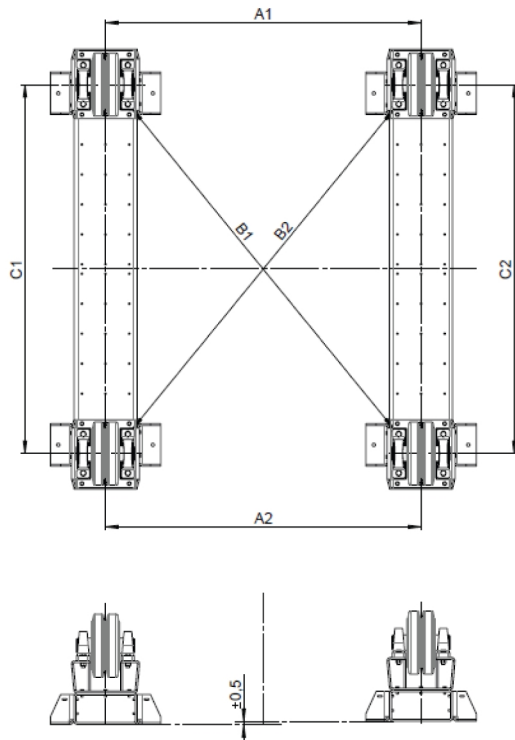

The illustration shows the correct alignment procedure between two roller bed sections (two idler units in the picture above).

Conventional roller bed alignment:

1. Ensure that the floor is leveled and free from cracks or other damages.
2. Ensure that heights are within limits.
3. Ensure that both sections have their wheel stands mounted at the corresponding place, i.e., C1 and C2 are equal.
4. Ensure that sections are not tilted.
5. Ensure that:  $A1 = A2 \pm 0.5 \text{ mm}$  (0.02 in.) and  $B1 = B2 \pm 0.5 \text{ mm}$  (0.02 in.).

## 5.7 Welding



### WARNING!

The vessel must be earthed independently from the roller beds when welding.

Earthing through the roller bed causes serious damage to the roller beds.

The earthing requirements of specific welding procedures must be known, and earthing should be correctly connected to the vessel before welding. Standard roller beds are not designed to earth the vessel during welding.

## 5.8 Stopping the roller beds

On the wireless remote - control pendant, press the toggling pushbutton for a continuous rotation to stop the rotation.

Rotation starts again when the pushbutton for continuously rotation is pressed.



### NOTE!

Use the emergency stop button on the control panel and wireless remote - control pendant in case of an emergency only.

---

## 6 MAINTENANCE

---

### 6.1 General

**WARNING!**

During all maintenance or repair procedures, the roller beds must be electrically isolated. Switch off the main electrical supply and unplug the mains cable.

**WARNING!**

After disconnecting the power, there may be some residual charge in some components in the panel. Wait for a few minutes after disconnecting the mains power before commencing work on any electrical elements of the roller bed.

The installation procedure must be carried out after maintenance, repair, or storage period, see section "Installation procedure".

### 6.2 Storage

Store the roller beds in a cool dry place. After a long period of storage, the roller beds must be thoroughly checked before use.

**WARNING!**

When the roller beds are stored or transported in a cold climate and moved into a warm location, condensation can be built up in the roller beds or the electrical controls. To prevent damage, allow the roller bed to adjust to the new environment temperature.

**CAUTION!**

Do not store the roller beds outside unprotected. The roller beds must be sheeted, bare metal areas, bearings, gears, and shafts suitably greased to prevent corrosion.

### 6.3 Repair and maintenance

Keep the roller beds clean and free from dirt or waste from the welding process.

Check the gearbox oil regularly and keep it at the correct levels. See the "Gearbox maintenance" section.

Inspect the entire roller beds installation at least once per year. Pay particular attention to:

- Electrical contacts
- Switches and controls
- Mechanical parts, fixings are not loose.
- Condition of PU wheels
- Wheel rotation is full and there is no eccentric rotation around the axles.
- Metal corrosion
- Frame damage
- Signs of damage to the wheel bearings
- Gearbox maintenance
- Cable damage: mains and any visible cable running from the control panel to the motors.
- Correct functioning of the emergency stops and the control panel mains switch.

Remove and replace any damaged parts.

## 6.4 Cleaning

**WARNING!**

Roller beds must be electrically isolated before cleaning. Electrical components must not come in contact with water or other cleaning fluids.

**NOTE!**

Ensure that the roller beds are clean. Any arc sparks, flux or slag must be removed from the roller beds as soon as possible.

Frequently check that the equipment is free from any damages, mechanical or electrical. At least one time a month.

The roller beds do not require any special cleaning instructions. The roller beds do not create any pollution to the environment around them during normal operation, although, the welding process being carried out on them may pollute the roller beds.

## 6.5 Breakdowns

If the roller beds stop working, the equipment must be repaired by authorized ESAB service technicians.

**NOTE!**

Repeated faults indicate a problem with the roller beds. Inform the person responsible for service and maintenance.

## 6.6 Gearmotors

### 6.6.1 Gearmotors inspection and maintenance

To ensure that the roller beds have a long service life the oil in the gearbox must be regularly checked and changed.

Regular maintenance checks:

- Under normal working conditions and with an oil sump temperature not exceeding 80 °C the service life of the oils is 10 000 operation hours or two years, whichever comes first.
- Check if the seal is leaking or damaged.
- Check if there are any unusual noises during operation. If yes, the bearing may be broken.
- Check the breathing hole of gearbox is obstruction free.
- To aid cooling of the gearbox it is recommended that the external housing is kept clean.
- Check the bolts, tighten if loose.

### 6.6.2 Gearbox lubrication

The gearboxes on the roller beds were filled with the proper quantity of lubricant (CLP ISO VG220: Fuchs Renolin CLP220) before shipping from the factory.

Oil charge per roller bed size:

Model	Volume per gearbox
ECD 7.5	0.7 dm <sup>3</sup>
ECD 15	1.1 dm <sup>3</sup>
ECD 30	2.1 dm <sup>3</sup>
ECD 60	3.2 dm <sup>3</sup>
ECD 90	6.4 dm <sup>3</sup>
ECD 120	9.7 dm <sup>3</sup>

All gearmotors are of Siemens brand.

More detailed information around maintenance of SIMOGEAR gearbox (BA 2030) and motors (BA2330) can be found at Siemens web site.

For changing gearbox oil and/or bearing lubrication follow the steps in chapter 8, Service and maintenance in respective manual by download the them from the following links:

BA 2030

<https://support.industry.siemens.com/cs/document/60666158/operating-instructions-ba-2030%3A-simogear-gearbox?dti=0&lc=en-DE>

BA 2330

<https://support.industry.siemens.com/cs/document/60666508/operating-instructions-ba-2330%3A-la-le-motors-for-mounting-on-simogear-gearboxes?dti=0&lc=en-DE>

In the manuals tables of recommended lubricant to use in gearboxes and bearings can be found.



**NOTE!**

Do not mix oils of different brands. Drain the oil from the gearbox before refilling with oil from a different brand.

## 6.7 Inverters

All inverters are of Siemens brand.

More detailed information around maintenance and troubleshooting of Sinamics V20 Inverter can be found at Siemens web site.

A new inverter with appropriate application software can be purchased from ESAB as a spare part.

## 6.8 Bearings



**NOTE!**

Before loosening the screws and nuts holding the bearing hubs, mark their position in relation to the wheel stand beneath, e.g., with a permanent marker. Do this to facilitate the remounting and aligning of the PU wheels afterward.

Make sure that the new bearings hubs are tightened to the correct torque.

M20 (8.8 quality) 385 Nm

M24 (8.8 quality) 665 Nm

## 6.9 PU wheels



**NOTE!**

Read section 6.8 Bearings before start replacing the PU Wheel.



Before replacing a PU Wheel, one of the bearing hubs needs to be removed. There is a locking screw located in the casted rim, which needs to be loosened before the PU Wheel can be pushed off the shaft. Before mounting the new PU Wheel, make sure that the shaft and keys are undamaged. Replace them if necessary.

## 7 TROUBLESHOOTING

Perform these checks and inspections before sending for an authorized service technician.

- Check that the control panel is connected to the correct mains voltage.
- Check that all three phases have live voltage (phase sequence is not significant).
- In a case where several roller beds are used in the same production area, make sure that correct wireless remote-control pendants are used to the corresponding receiver unit that is mounted behind the control panel. (Serial no., ID would be the same on all units belonging to the same ECD).
- Check that the mains supply is disconnected before starting any type of repair action.

Type of fault	Possible cause	Corrective action
Power light is not illuminated	No incoming power	Check the incoming mains power
	Possible phase loss	Check that all phases are present
	Faulty or tripped circuit breaker	Check reset circuit breaker
Failure to reset when reset button is pressed	Emergency stop pressed	Check that all emergency stops are reset
	Circuit breaker has tripped	Check and reset tripped breaker(s)
	Low voltage power failure	Check output from low voltage power supply (24 V)
No rotation (alarm ON)	Wireless remote does not communicate with the receiver attached to the control panel	Ensure the correct transmitter is in use. The labels on the receiver and the transmitter will identify the RF channel and ID code in use
	Inverter not receiving speed reference	Make sure the wireless control has a full charged battery
	A pushbutton is stuck to the bottom and does not release	Check that pushbutton on the wireless control for any damage
	No power from the inverter	Check if the inverter has proper power supply. Service Manual 0463762001 will give more information about fault tracing.
The roller bed rotates but wheels are juddering	Motor fault	Check that motor turns freely
	Wheel bearing fault	Check for damage or play in bearing
The roller bed struggles to turn component	Work piece exceeds capacity of the roller bed	Check component weight
	Wheel centres are too far apart	Check that wheel centres are correct to component diameter
	Out of balance loading has been exceeding	Check if out of balance loading is acceptable

## 8 ORDERING SPARE PARTS

---



**CAUTION!**

Repair and electrical work should be performed by an authorised ESAB service technician. Use only ESAB original spare and wear parts.

ECD 7.5 and ECI 7.5, ECD 15 and ECI 15, ECD 30 and ECI 30, ECD 60 and ECI 60, ECD 90 and ECI 90, ECD 120 and ECI 120 are designed and tested in accordance with the international and European standards **EN 12100:2010**, **EN 60204-1:2018**, **EN 61000-6-2:2019** and **EN 61000-6-4:2019**. On completion of service or repair work, it is the responsibility of the person(s) performing the work to ensure that the product still complies with the requirements of the above standards.

Spare parts and wear parts can be ordered through your nearest ESAB dealer, see [esab.com](https://www.esab.com). When ordering, please state product type, serial number, designation and spare part number in accordance with the spare parts list. This facilitates dispatch and ensures correct delivery.

# APPENDIX

## WIRING DIAGRAM

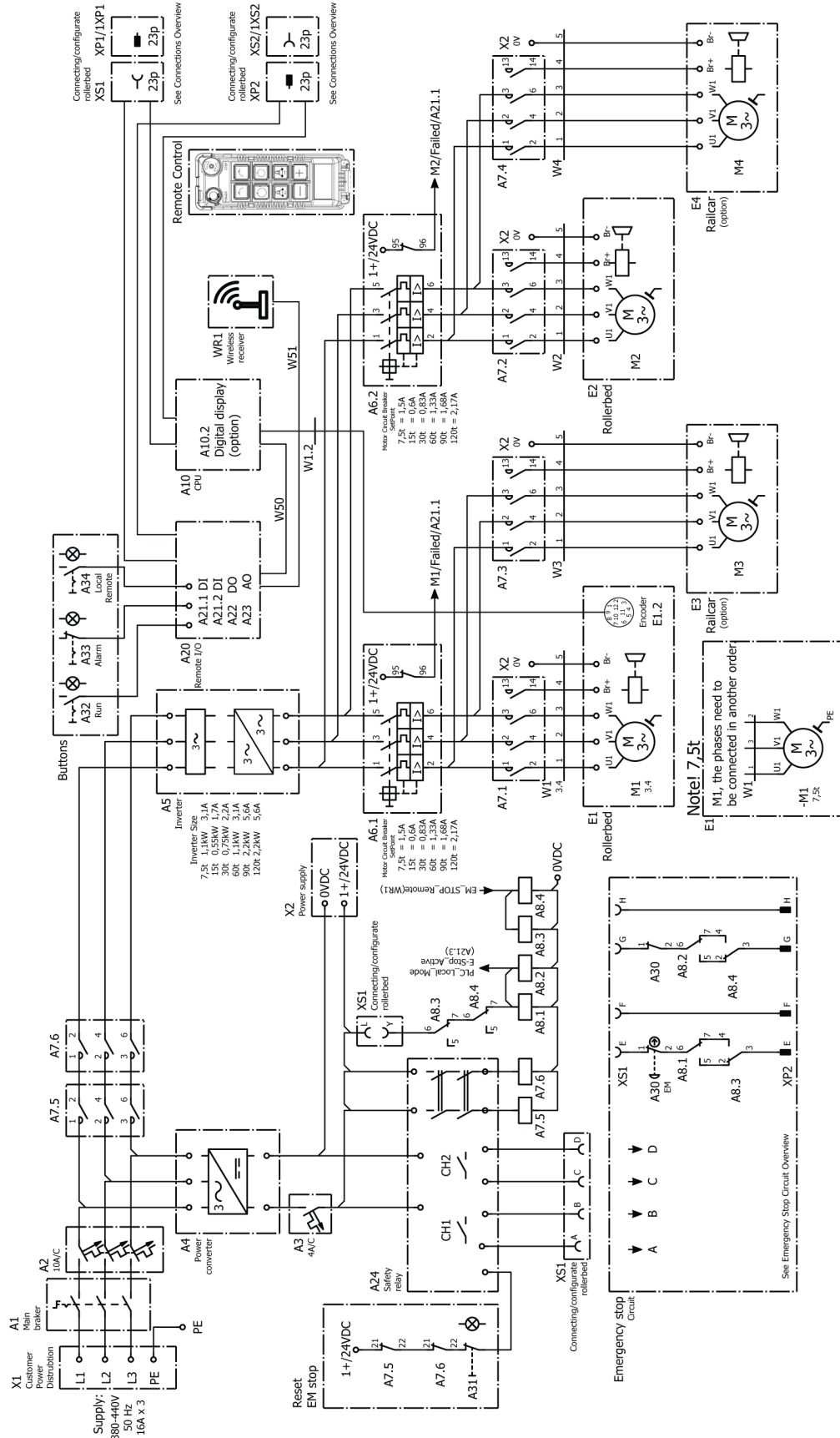

Connections overview

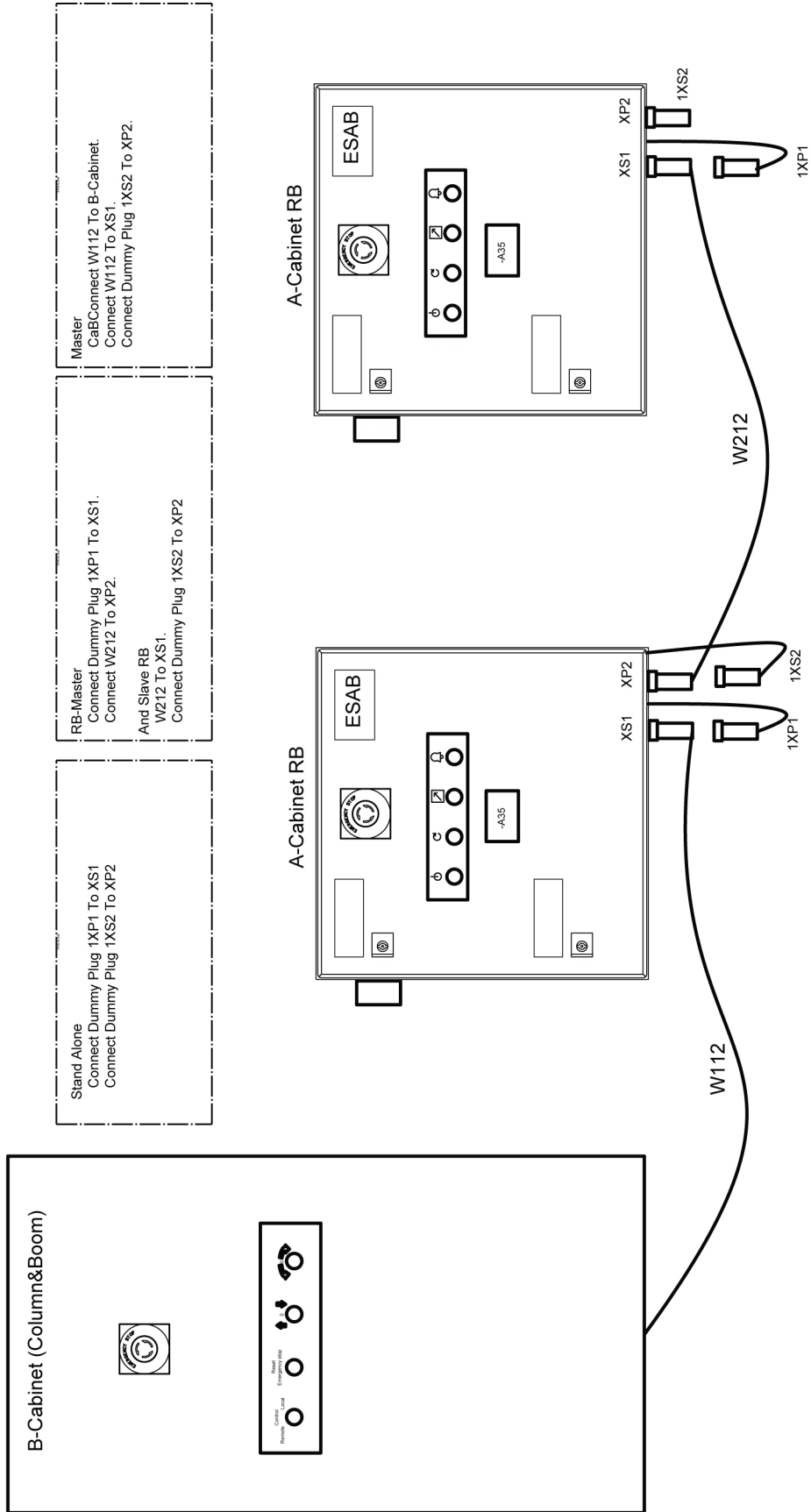

Connections B to A cabinet and primary to secondary

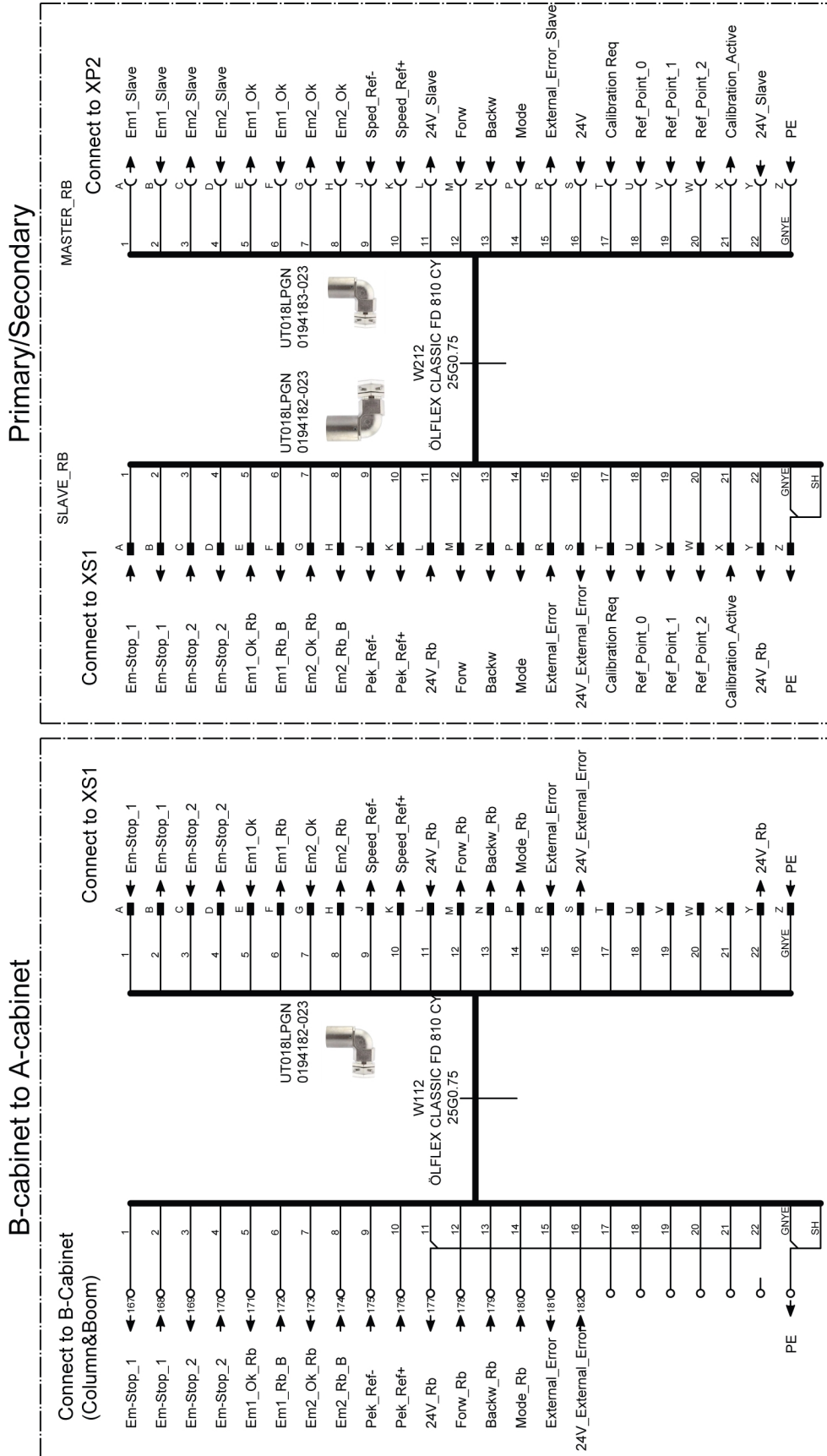

Connections XS1 and XP2

PIN PLUG-23PIN  
0368541-005

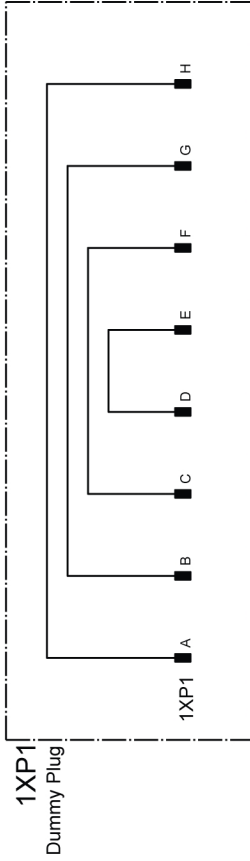

SOCKET PLUG-23PIN  
0368542-005

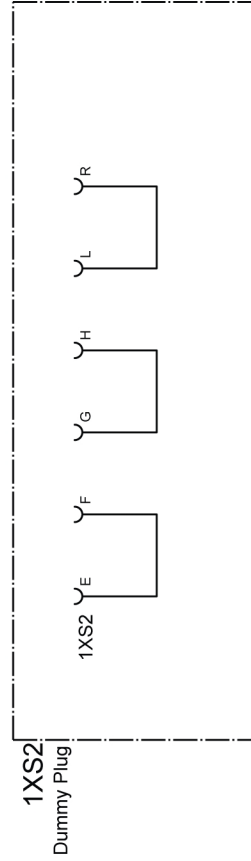

OVERVIEW A-Cabinet  
XS1 AND XP2

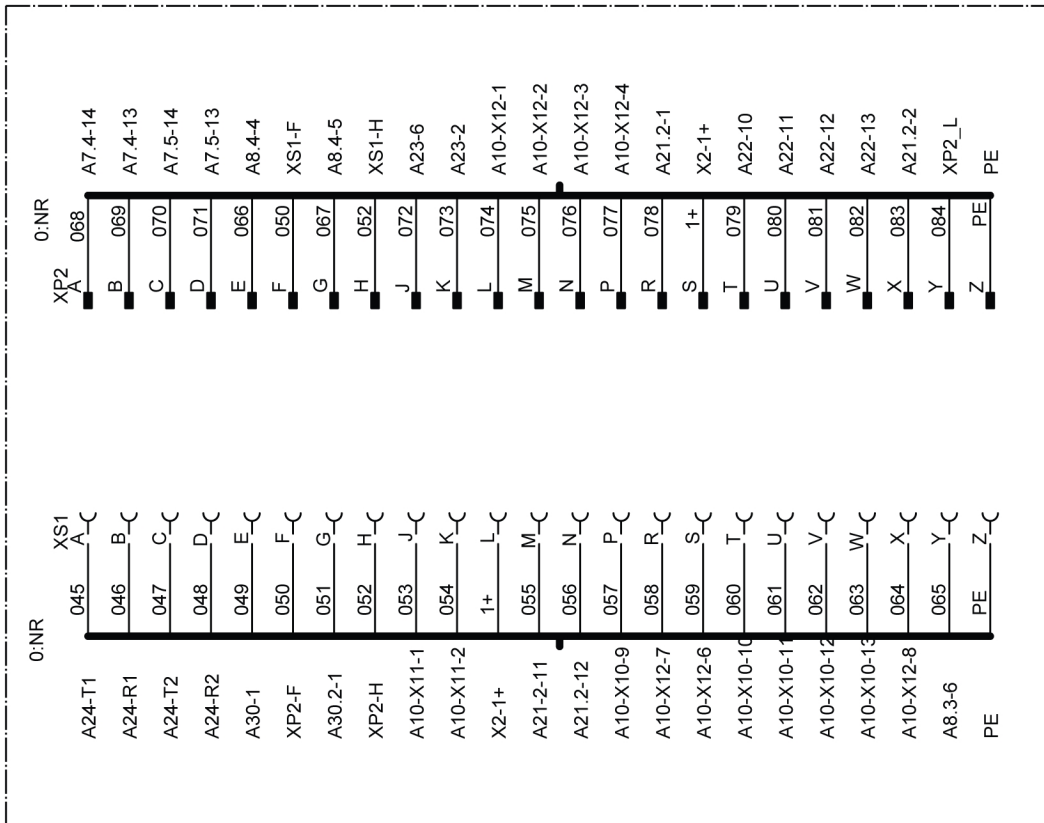

Emergency stop circuit overview

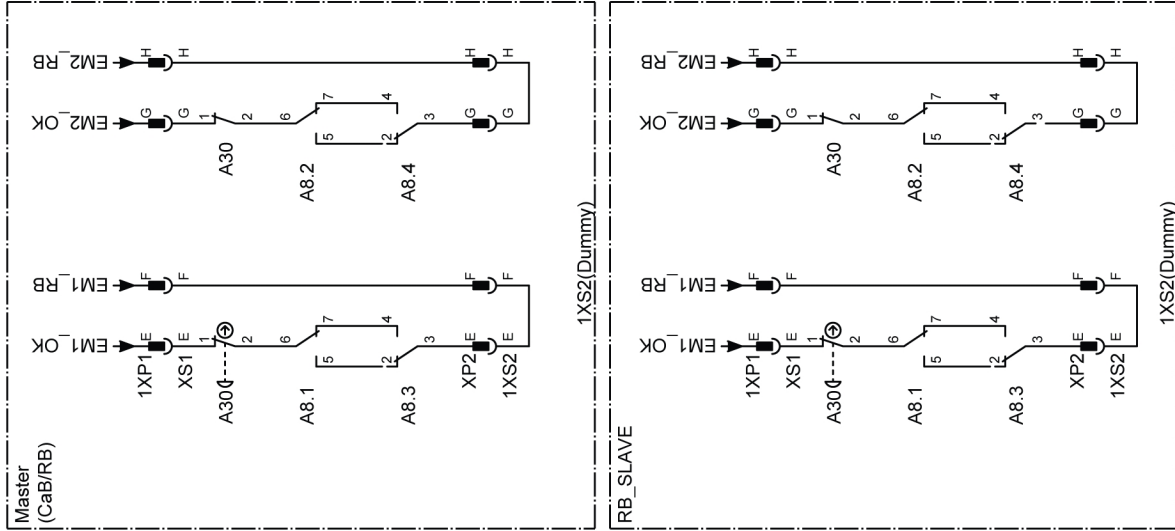

MASTER (Column&Boom) Master CaB = Connect W112 To B-Cabinet.  
Connect W112 To RB- XS1.  
Connect Dummy Plug 1XS2 To RB- XP2.

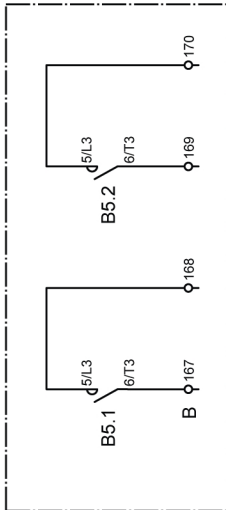

RB-MASTER = Connect Dummy Plug 1XP1 To RB- XS1.  
and  
Connect W212 To RB- XP2.  
Slave RB= W212 To RB- XS1.  
Connect Dummy Plug 1XS2 To RB- XP2

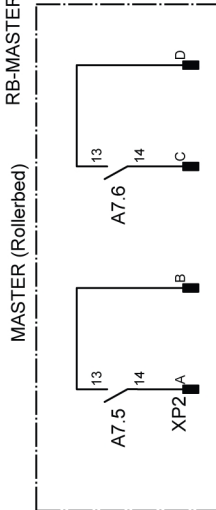

Stand Alone = Connect Dummy Plug 1XP1 To RB- XS1  
Connect Dummy Plug 1XS2 To RB-XP2

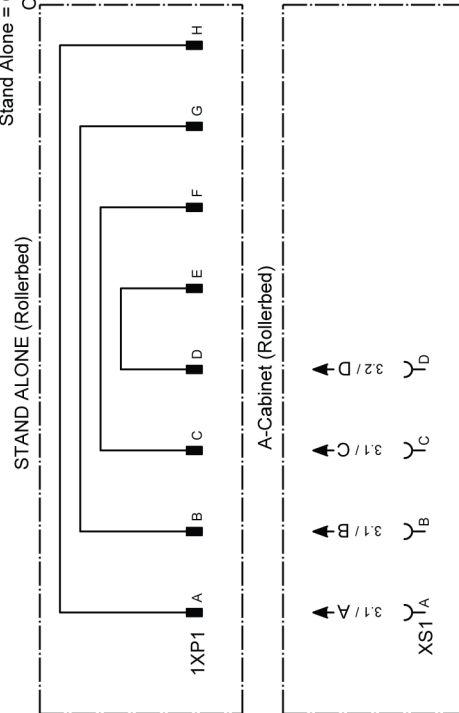



## ORDERING NUMBERS

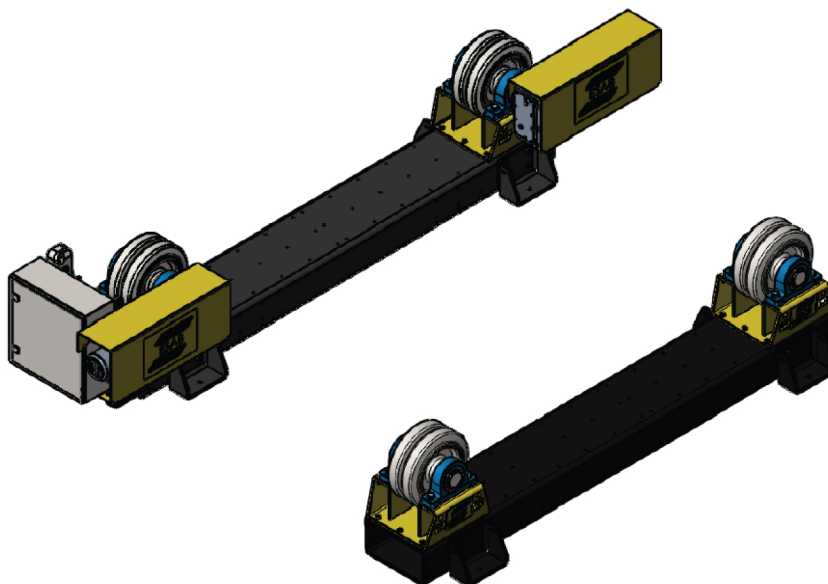

Ordering number	Denomination	Type	Notes
0909 250 880	Roller bed drive unit	ECD 7.5	CE
0909 250 881	Roller bed drive unit	ECD 7.5	CE, with digital display
0909 251 880	Roller bed idler unit	ECI 7.5	
0909 000 880	Roller bed drive unit	ECD 15	CE
0909 000 881	Roller bed drive unit	ECD 15	CE, with digital display
0909 001 880	Roller bed idler unit	ECI 15	
0909 002 880	Roller bed drive unit	ECD 30	CE
0909 002 881	Roller bed drive unit	ECD 30	CE, with digital display
0909 003 880	Roller bed idler unit	ECI 30	
0909 004 880	Roller bed drive unit	ECD 60	CE
0909 004 881	Roller bed drive unit	ECD 60	CE, with digital display
0909 005 880	Roller bed idler unit	ECI 60	
0909 006 880	Roller bed drive unit	ECD 90	CE
0909 006 881	Roller bed drive unit	ECD 90	CE, with digital display
0909 007 880	Roller bed idler unit	ECI 90	
0909 008 880	Roller bed drive unit	ECD 120	CE
0909 008 881	Roller bed drive unit	ECD 120	CE, with digital display
0909 009 880	Roller bed idler unit	ECI 120	

## ACCESSORIES

Qty	Ordering no.	Denomination	Notes
1	0909 530 880	CaB integration cable, CE	10 m
1	0909 530 881	CaB integration cable, CE	20 m
1	0909 530 882	CaB integration cable, CE	30 m
1	0909 530 883	CaB integration cable, CE	40 m
1	0909 530 884	CaB integration cable, CE	50 m
1	0909 530 900	Synchronization cable, CE	10 m
1	0909 530 901	Synchronization cable, CE	20 m
1	0909 530 902	Synchronization cable, CE	30 m
1	0909 530 903	Synchronization cable, CE	40 m
1	0909 530 904	Synchronization cable, CE	50 m

## SPARE PARTS

### Repairs and replacement parts

During the warranty period repairs must be carried out under the direction of the manufacturers. Any unauthorized repairs may damage the roller beds and invalidate the warranty.

It is recommended to contact the the manufacturer for the supply of all replacement parts. This ensures that the correct part or suitable alternative parts are supplied and used in the equipment.



#### **WARNING!**

Not following the recommendations for replacement parts can have consequences for the safety of the equipment. The manufacturers cannot be held liable for any subsequent problems after fitting non-recommended parts.

## SPARE PARTS - ECD 7.5 Mechanical parts list - Drive section

Item	Qty	Ordering no.	Denomination	Notes
1	1	0909 229 001	Base frame	300×200×12, L=2200
2	2	0909 243 880	Wheel stand	
3	4	0909 037 001	Side support	
4	2	0909 164 001	PU wheel	300×90
5	2	0909 236 001	Drive shaft	
6	4	0909 244 001	Wheel shaft bearing	UCP210
7	2	0215 701 343	Key, wheel	14×9×90
8	2	0215 701 278	Key, gearmotor	8×7×90
9.a	1	0909 239 005	Gearmotor left	0.25 kW
9.b	1	0909 239 006	Gearmotor right	0.25 kW
10	2	0909 240 001	Torque stop	
11	2	0909 241 001	Cover	
11.a	2	0909 296 880	Bracket cover	Not shown in illustration
12	1	0909 104 001	Bracket	
13	1	0909 242 001	Bracket	

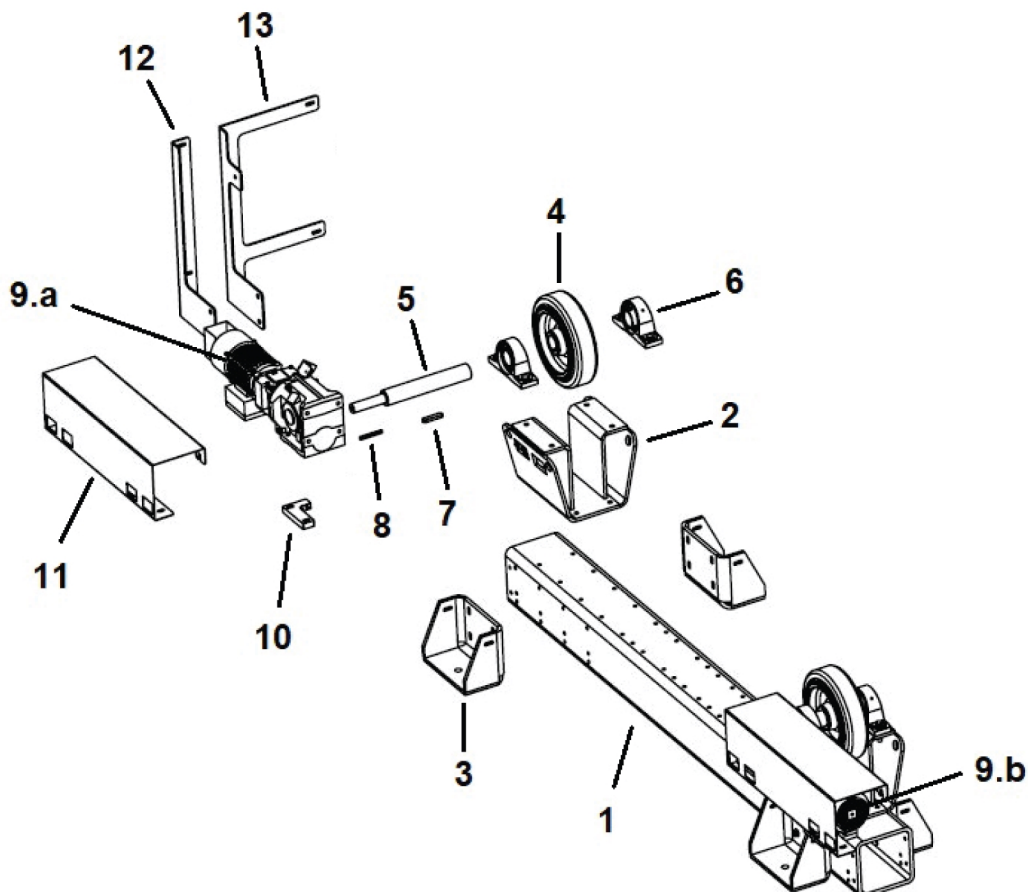

## SPARE PARTS - ECI 7.5 Mechanical parts list - Idler section

Item	Qty	Ordering no.	Denomination	Notes
1	1	0909 229 001	Base frame	200×200×12, L=2200
2	2	0909 243 880	Wheel stand	
3	4	0909 037 001	Side support	
4	2	0909 164 001	PU wheel	300×90
5	2	0909 237 001	Idler shaft	
6	4	0909 244 001	Wheel shaft bearing	UCP210
7	2	0215 701 343	Key	14×9×70

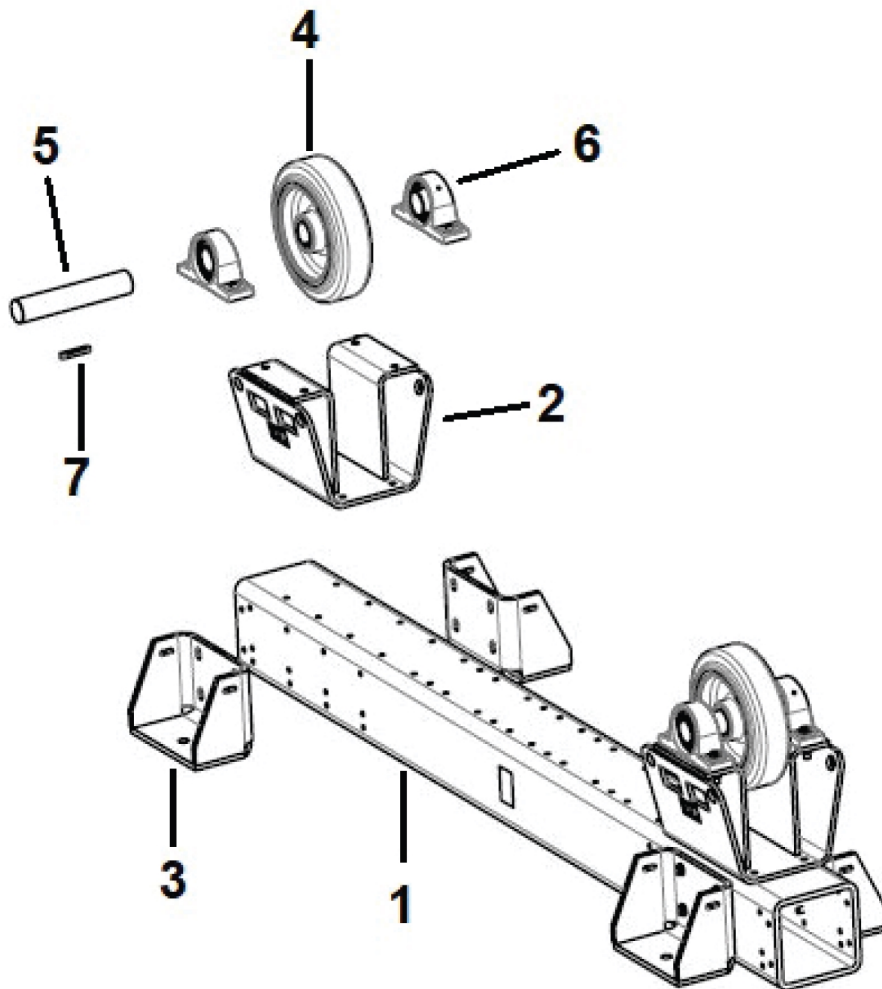

## SPARE PARTS - ECD 15 Mechanical parts list - Drive section

Item	Qty	Ordering no.	Denomination	Notes
1	1	0909 043 001	Base frame	300×200×12, L=2790
2	2	0909 045 880	Wheel stand	
3	4	0909 037 001	Side support	
4	2	0909 076 001	PU wheel	400×90
5	2	0909 369 001	Drive shaft	
6	4	0909 049 001	Wheel shaft bearing	UCP214
7	2	0215 701 420	Key, wheel	20×12×70
8	2	0215 701 332	Key, gearmotor	12×8×110
9.a	1	0909 080 001	Gearmotor left	0.18 kW Valid for serial no. 950-xxx-xxxx
9.a	1	0909 361 001	Gearmotor left v2	0.18 kW Valid for serial no. 130-xxx-xxxx
9.b	1	0909 080 002	Gearmotor right	0.18 kW Valid for serial no. 950-xxx-xxxx
9.b	1	0909 361 002	Gearmotor right v2	0.18 kW Valid for serial no. 130-xxx-xxxx
10	2	0909 126 001	Torque stop	Valid for serial no. 950-xxx-xxxx
10	2	0909 370 001	Torque stop v2	Valid for serial no. 130-xxx-xxxx
11	2	0909 073 001	Cover	Valid for serial no. 950-xxx-xxxx
11	2	0909 368 001	Cover v2	Valid for serial no. 130-xxx-xxxx
11.2	2	0909 269 880	Bracket cover v2	Valid for serial no. 130-xxx-xxxx Not shown in illustration
12	1	0909 104 001	Bracket	
13	1	0909 116 001	Bracket	

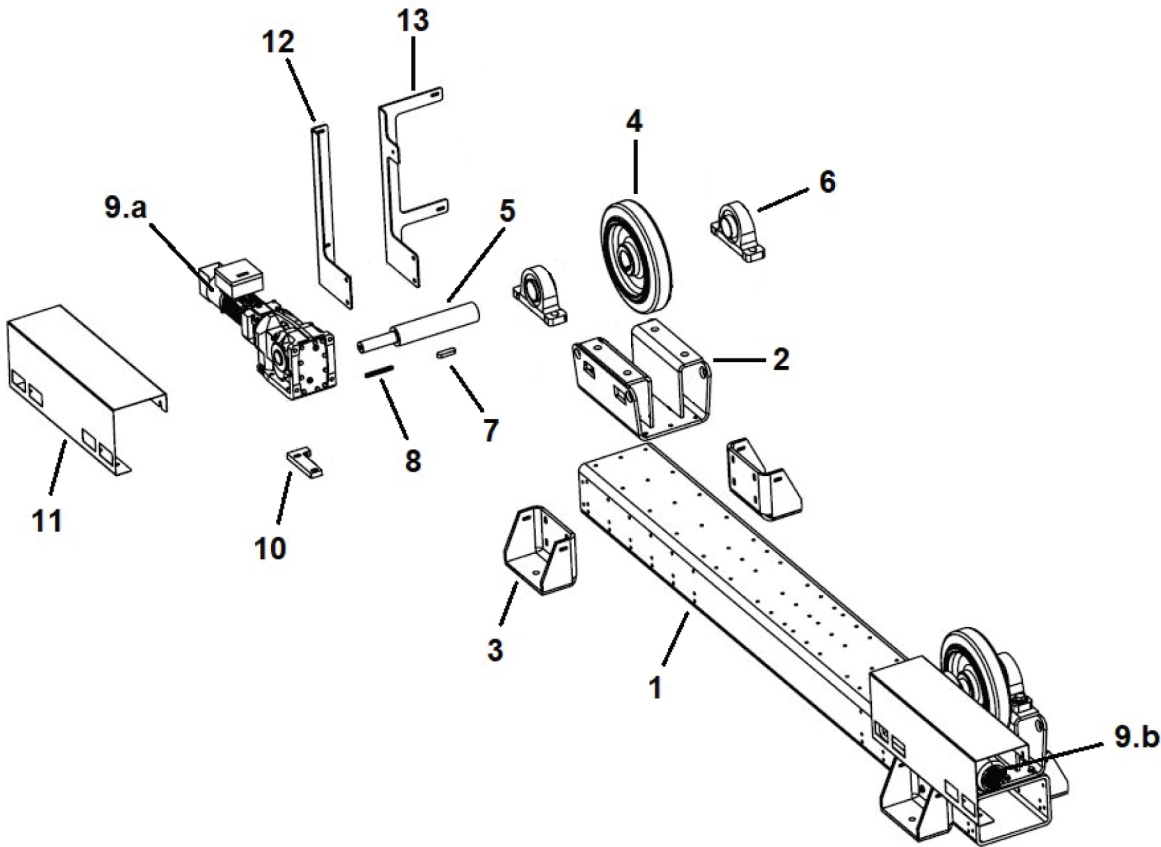

## SPARE PARTS - ECI 15 Mechanical parts list - Idler section

Item	Qty	Ordering no.	Denomination	Notes
1	1	0909 043 001	Base frame	300×200×12, L=2790
2	2	0909 045 880	Wheel stand	
3	4	0909 037 001	Side support	
4	2	0909 076 001	PU wheel	400×90
5	2	0909 044 001	Idler shaft	
6	4	0909 049 001	Wheel shaft bearing	UCP214
7	2	0215 701 420	Key	20×12×70

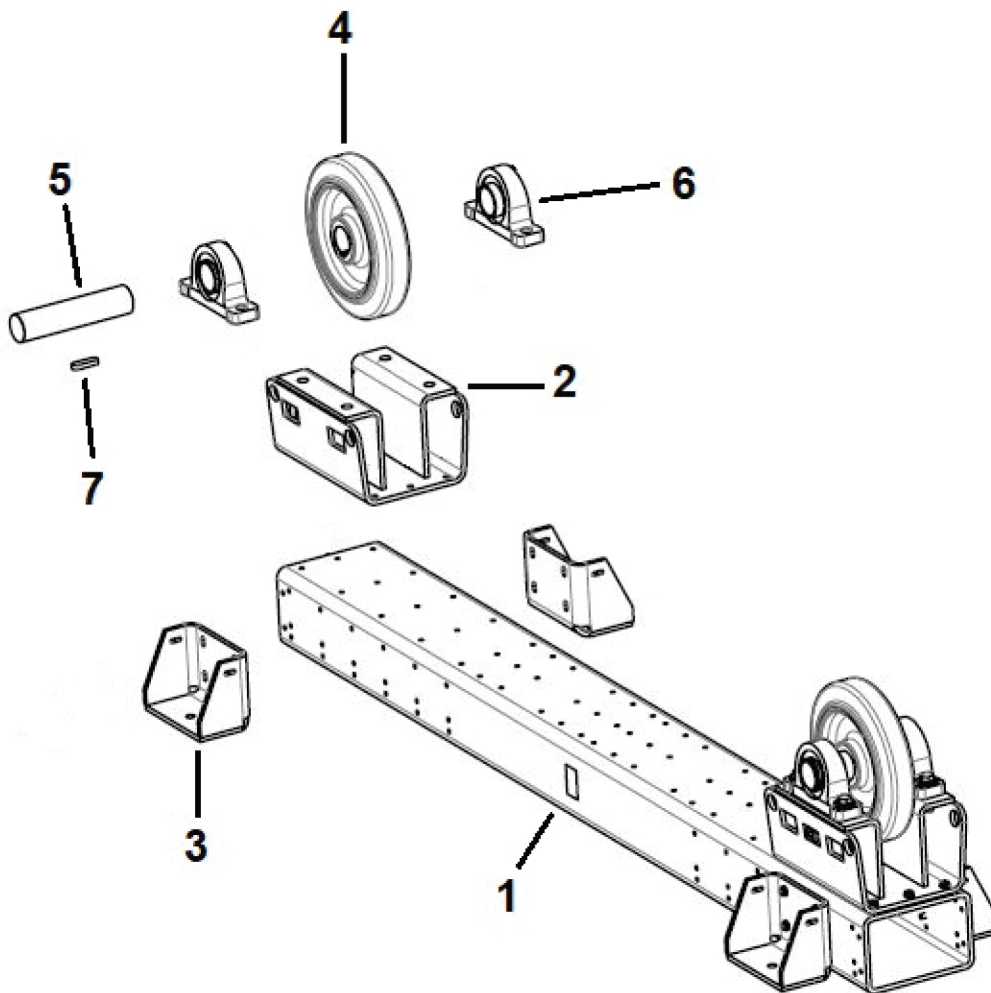



## SPARE PARTS - ECD 30 Mechanical parts list - Drive section

Item	Qty	Ordering no.	Denomination	Notes
1	1	0909 035 001	Base frame	400×200×12, L=2790
2	2	0909 036 880	Wheel stand	
3	4	0909 037 001	Side support	
4	4	0909 057 001	PU wheel	400×90
5	2	0909 051 001	Drive shaft	Valid for serial no. 950-xxx-xxxx
5	2	0909 357 001	Drive shaft v2	Valid for serial no. 130-xxx-xxxx
6	4	0909 059 001	Wheel shaft bearing	UCP 217-LBS
7	2	0215 701 431	Key, wheel	22×14×160
8	2	0215 701 347	Key, gearmotor	14×9×125
9.a	1	0909 058 001	Gearmotor left	0.37 kW Valid for serial no. 950-xxx-xxxx
9.a	1	0909 362 001	Gearmotor left v2	0.37 kW Valid for serial no. 130-xxx-xxxx
9.b	1	0909 058 002	Gearmotor right	0.37 kW Valid for serial no. 950-xxx-xxxx
9.b	1	0909 362 002	Gearmotor right v2	0.37 kW Valid for serial no. 130-xxx-xxxx
10	2	0909 138 001	Torque stop	Valid for serial no. 950-xxx-xxxx
10	2	0909 359 001	Torque stop v2	Valid for serial no. 130-xxx-xxxx
11	2	0909 042 001	Cover	Valid for serial no. 950-xxx-xxxx
11	2	0909 358 001	Cover v2	Valid for serial no. 130-xxx-xxxx
11.2	2	0909 296 880	Bracket cover v2	Valid for serial no. 130-xxx-xxxx Not shown in illustration
12	1	0909 104 001	Bracket	
13	1	0909 117 001	Bracket	

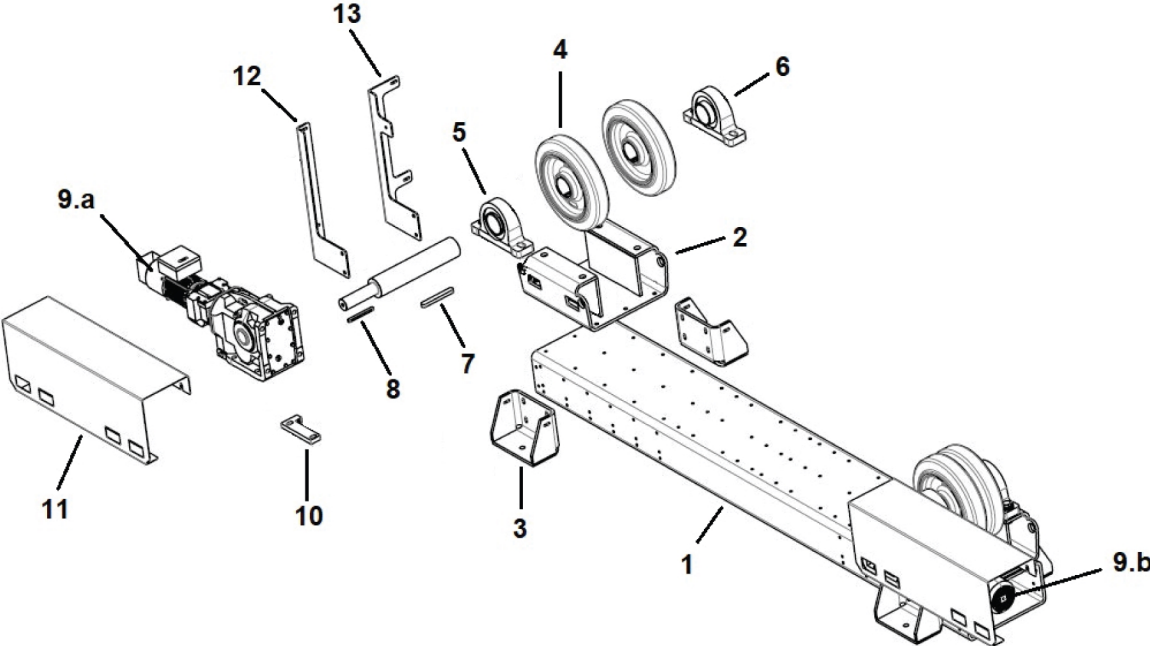

## SPARE PARTS - ECI 30 Mechanical parts list - Idler section

Item	Qty	Ordering no.	Denomination	Notes
1	1	0909 035 001	Base frame	400x200x12, L=2790
2	2	0909 036 880	Wheel stand	
3	4	0909 037 001	Side support	
4	4	0909 057 001	PU wheel	400x90
5	2	0909 038 001	Idler shaft	
6	4	0909 059 001	Wheel shaft bearing	UCP 217-LBS
7	2	0215 705 912	Key	22x14x90

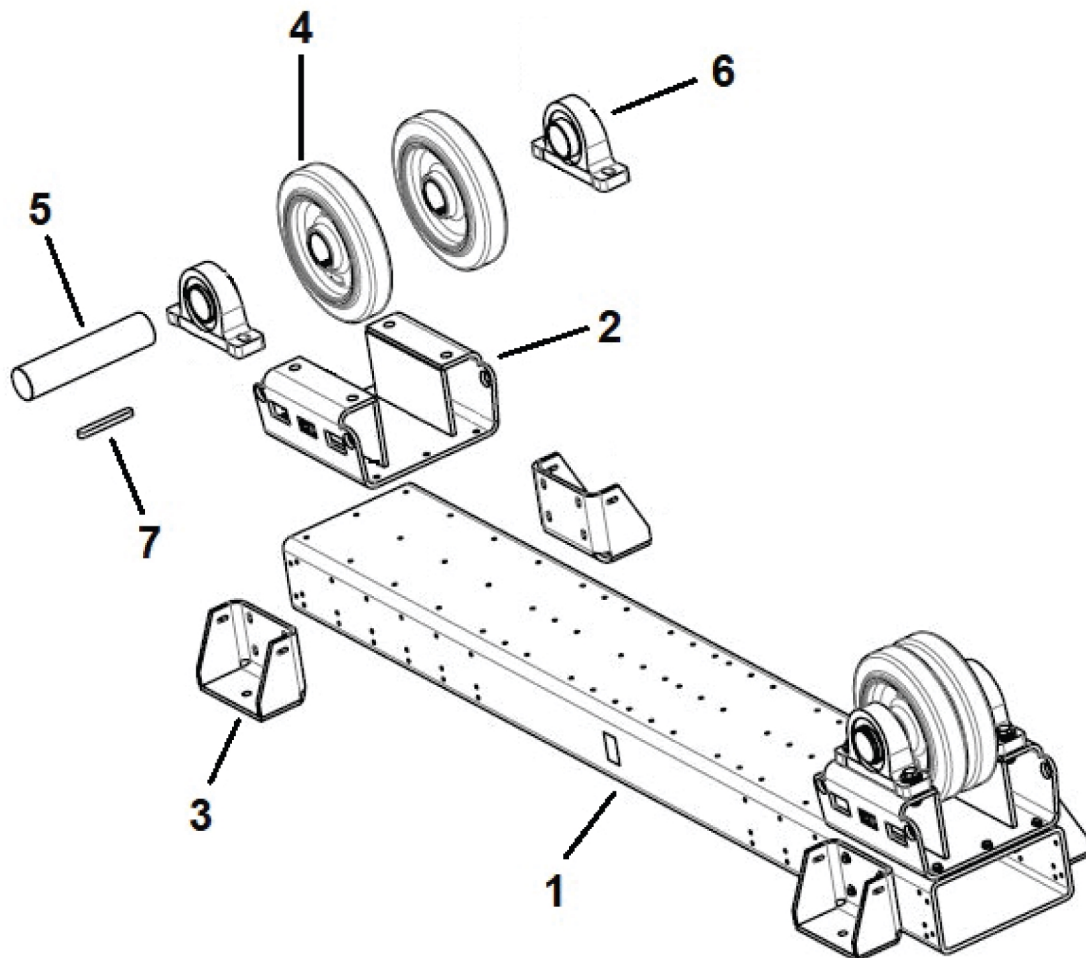

## SPARE PARTS - ECD 60 Mechanical parts list - Drive section

Item	Qty	Ordering no.	Denomination	Notes
1	1	0909 088 001	Base frame	400×200×16, L=3650
2	2	0909 089 880	Wheel stand	
3	4	0909 098 001	Side support	
4	4	0909 096 001	PU wheel	580×180
5	2	0909 094 001	Drive shaft	
6	4	0909 097 880	Wheel shaft bearing	SNL519
7	2	0215 701 430	Key, wheel	22×14×140
8	2	0215 701 412	Key, gearmotor	18×11×160
9.a	1	0909 095 001	Gearmotor left	0.75 kW Valid for serial no. 950-xxx-xxxx
9.a	1	0909 363 001	Gearmotor left v2	0.75 kW Valid for serial no. 130-xxx-xxxx
9.b	1	0909 095 002	Gearmotor right	0.75 kW Valid for serial no. 950-xxx-xxxx
9.b	1	0909 363 002	Gearmotor right v2	0.75 kW Valid for serial no. 130-xxx-xxxx
10	2	0909 128 001	Torque stop	Valid for serial no. 950-xxx-xxxx
10	2	0909 374 001	Torque stop v2	Valid for serial no. 130-xxx-xxxx
11	2	0909 110 001	Cover	Valid for serial no. 950-xxx-xxxx
11	2	0909 373 001	Cover v2	Valid for serial no. 130-xxx-xxxx
11.2	2	0909 296 880	Bracket cover v2	Valid for serial no. 130-xxx-xxxx Not shown in illustration
13	1	0909 104 001	Bracket	
14	1	0909 117 001	Bracket	

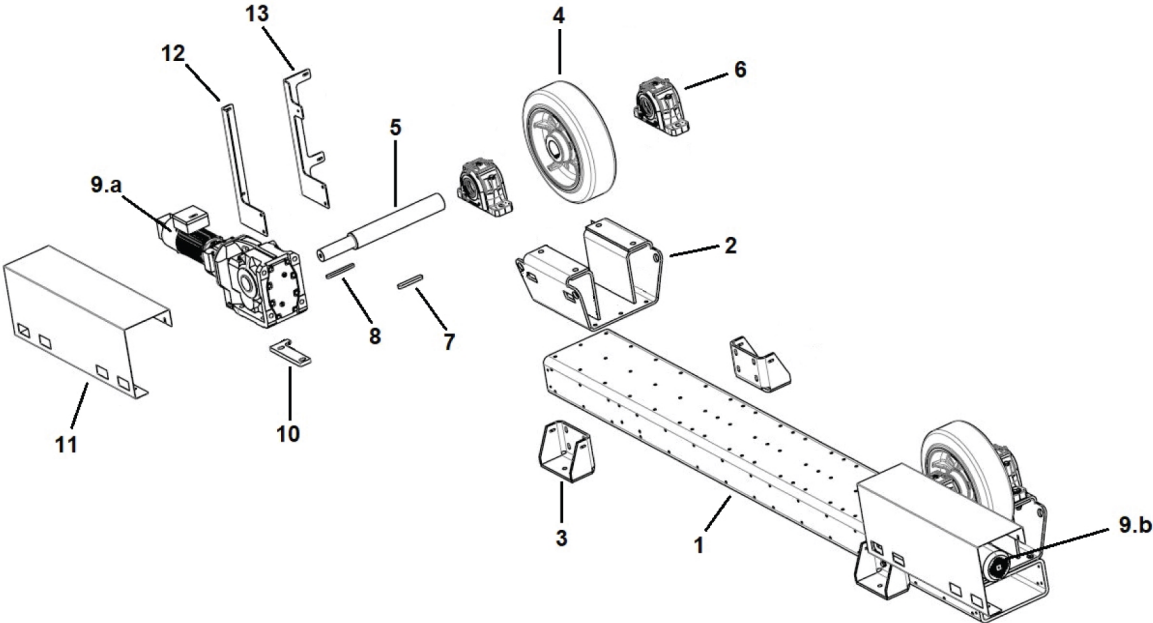

## SPARE PARTS - ECI 60 Mechanical parts list - Idler section

Item	Qty	Ordering no.	Denomination	Notes
1	1	0909 088 001	Base frame	400×200×16, L=3650
2	2	0909 089 880	Wheel stand	
3	4	0909 098 001	Side support	
4	4	0909 096 001	PU wheel	
5	2	0909 093 001	Idler shaft	
6	4	0909 097 880	Wheel shaft bearing	SNL519
7	2	0215 701 430	Key	22×14×140

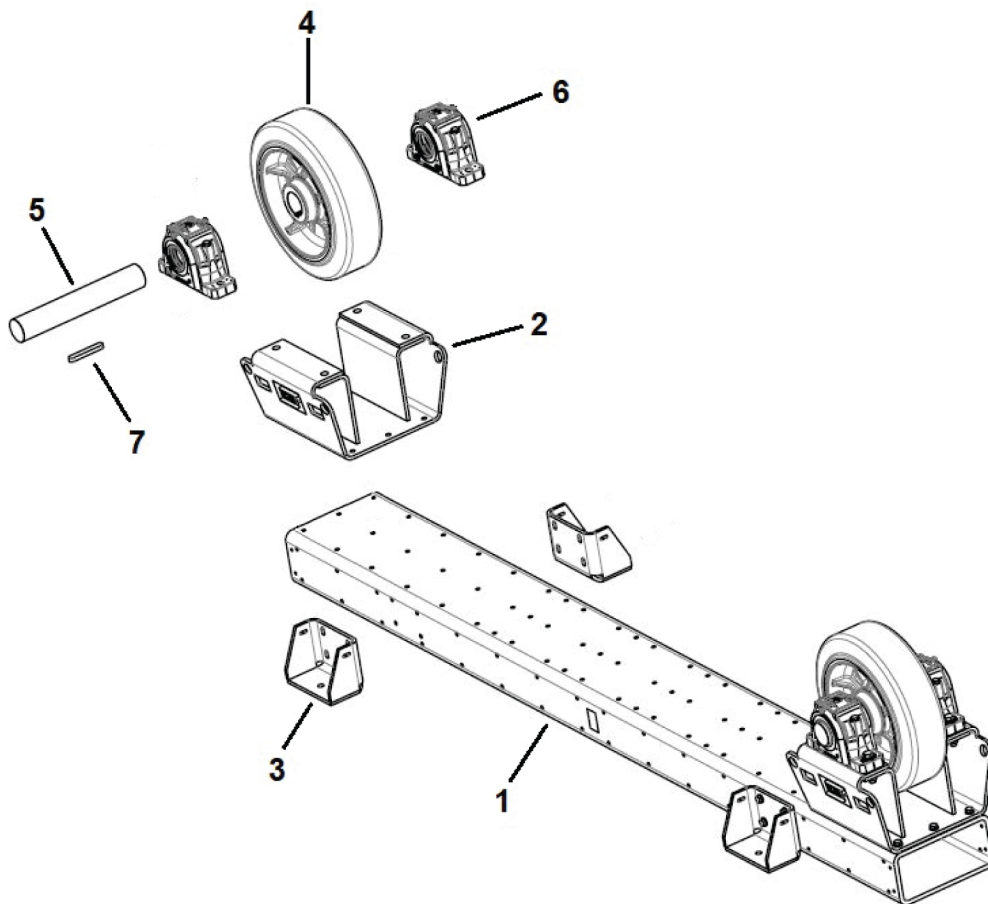

## SPARE PARTS - ECD 90 Mechanical parts list - Drive section

Item	Qty	Ordering no.	Denomination	Notes
1	1	0909 387 001	Base frame	500×200×16, L=3650
2	2	0909 083 880	Wheel stand	
3	4	0909 098 001	Side support	
4	2	0909 072 001	PU wheel	580×250
5	2	0909 086 001	Drive shaft	
6	4	0909 097 880	Wheel shaft bearing	SNT519
7	2	0215 705 911	Key, wheel	
8	2	0215 701 427	Key, gearmotor	22×12×240
9.a	1	0909 060 001	Gearmotor left	1.00 kW Valid for serial no. 950-xxx-xxxx
9.a	1	0909 364 001	Gearmotor left v2	1.00 kW Valid for serial no. 130-xxx-xxxx
9.b	1	0909 060 002	Gearmotor right	1.00 kW Valid for serial no. 950-xxx-xxxx
9.b	1	0909 364 002	Gearmotor right v2	1.00 kW Valid for serial no. 130-xxx-xxxx
10	2	0909 084 001	Torque stop	Valid for serial no. 950-xxx-xxxx
10	2	0909 378 001	Torque stop v2	Valid for serial no. 130-xxx-xxxx
11	2	0909 087 001	Cover	Valid for serial no. 950-xxx-xxxx
11	2	0909 377 001	Cover v2	Valid for serial no. 130-xxx-xxxx
11.2	2	0909 296 880	Bracket cover v2	Valid for serial no. 130-xxx-xxxx Not shown in illustration
12	1	0909 104 001	Bracket	
13	1	0909 118 001	Bracket	

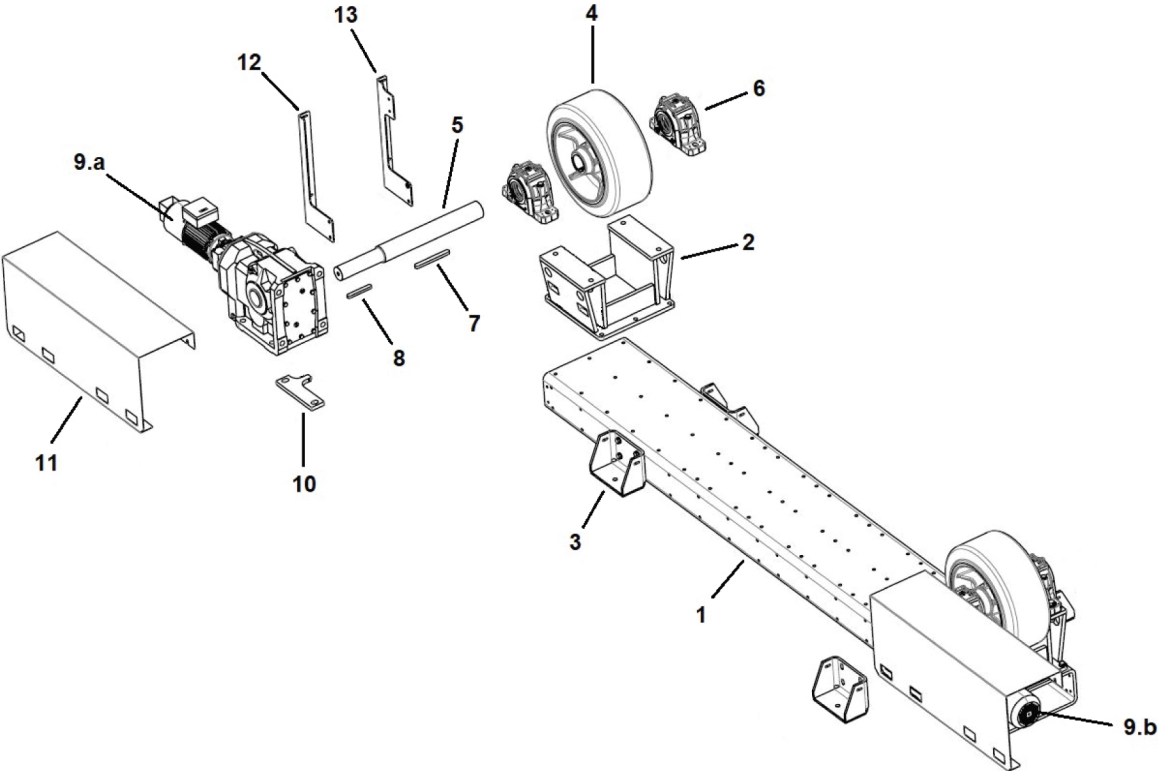



## SPARE PARTS - ECI 90 Mechanical parts list - Idler section

Item	Qty	Ordering no.	Denomination	Notes
1	1	0909 387 001	Base frame	
2	2	0909 083 880	Wheel stand	
3	4	0909 098 001	Side support	
4	2	0909 072 001	PU wheel	580×250
5	2	0909 075 001	Idler shaft	
6	4	0909 097 880	Wheel shaft bearing	SNT519
7	2	0215 705 911	Key	

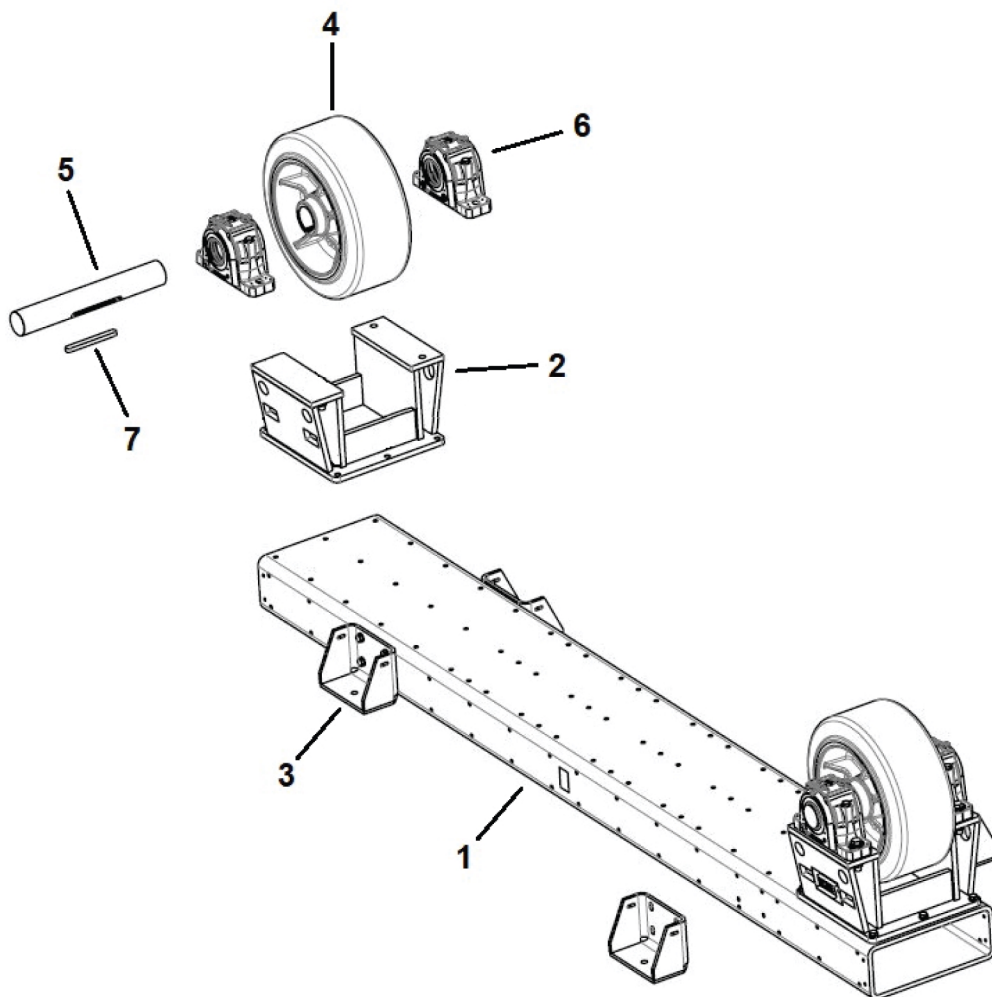

## SPARE PARTS - ECD 120 Mechanical parts list - Drive section

Item	Qty	Ordering no.	Denomination	Notes
1	1	0909 108 880	Base frame	600×200×16, L=3650
2	2	0909 106 880	Wheel stand	
3	4	0909 098 001	Side support	
4	4	0909 101 001	PU wheel	580×180
5	2	0909 113 001	Drive shaft	
6	4	0909 109 880	Wheel shaft bearing	SNL524
7	4	0215 701 448	Key	28×16×140
8	2	0215 701 441	Key	25×14×200
9.a	2	0909 105 001	Gearmotor left	1.50 kW Valid for serial no. 950-xxx-xxxx
9.a	2	0909 365 001	Gearmotor left v2	1.50 kW Valid for serial no. 130-xxx-xxxx
9.b	2	0909 105 002	Gearmotor right	1.50 kW Valid for serial no. 950-xxx-xxxx
9.b	2	0909 365 002	Gearmotor right v2	1.50 kW Valid for serial no. 130-xxx-xxxx
10	2	0909 114 880	Torque stop	Valid for serial no. 950-xxx-xxxx
10	2	0909 382 880	Torque stop v2	Valid for serial no. 130-xxx-xxxx
11	2	0909 115 001	Cover	Valid for serial no. 950-xxx-xxxx
11	2	0909 381 001	Cover v2	Valid for serial no. 130-xxx-xxxx
11.2	2	0909 296 880	Bracket cover v2	Valid for serial no. 130-xxx-xxxx Not shown in illustration
12	1	0909 104 001	Bracket	
13	1	0909 119 001	Bracket	

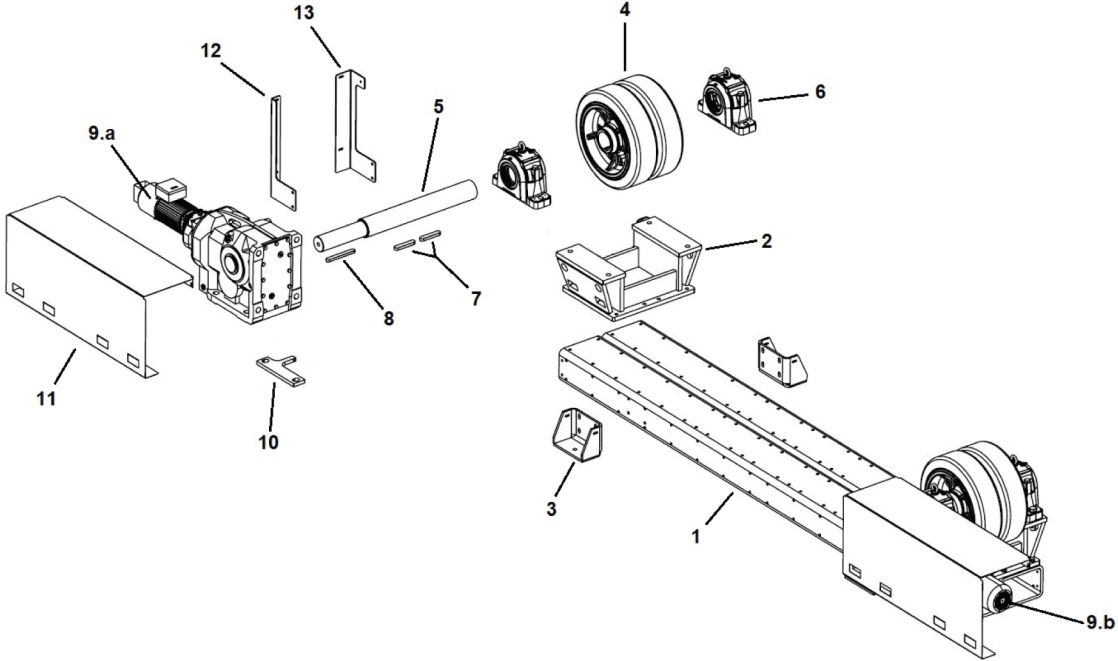

## SPARE PARTS - ECI 120 Mechanical parts list - Idler section

Item	Qty	Ordering no.	Denomination	Notes
1	1	0909 108 880	Base frame	
2	2	0909 106 880	Wheel stand	
3	4	0909 098 001	Side support	
4	4	0909 101 001	PU wheel	580x180
5	2	0909 079 001	Idler shaft	
6	4	0909 109 880	Wheel shaft bearing	SNT524
7	4	0215 701 448	Key	28×16×140

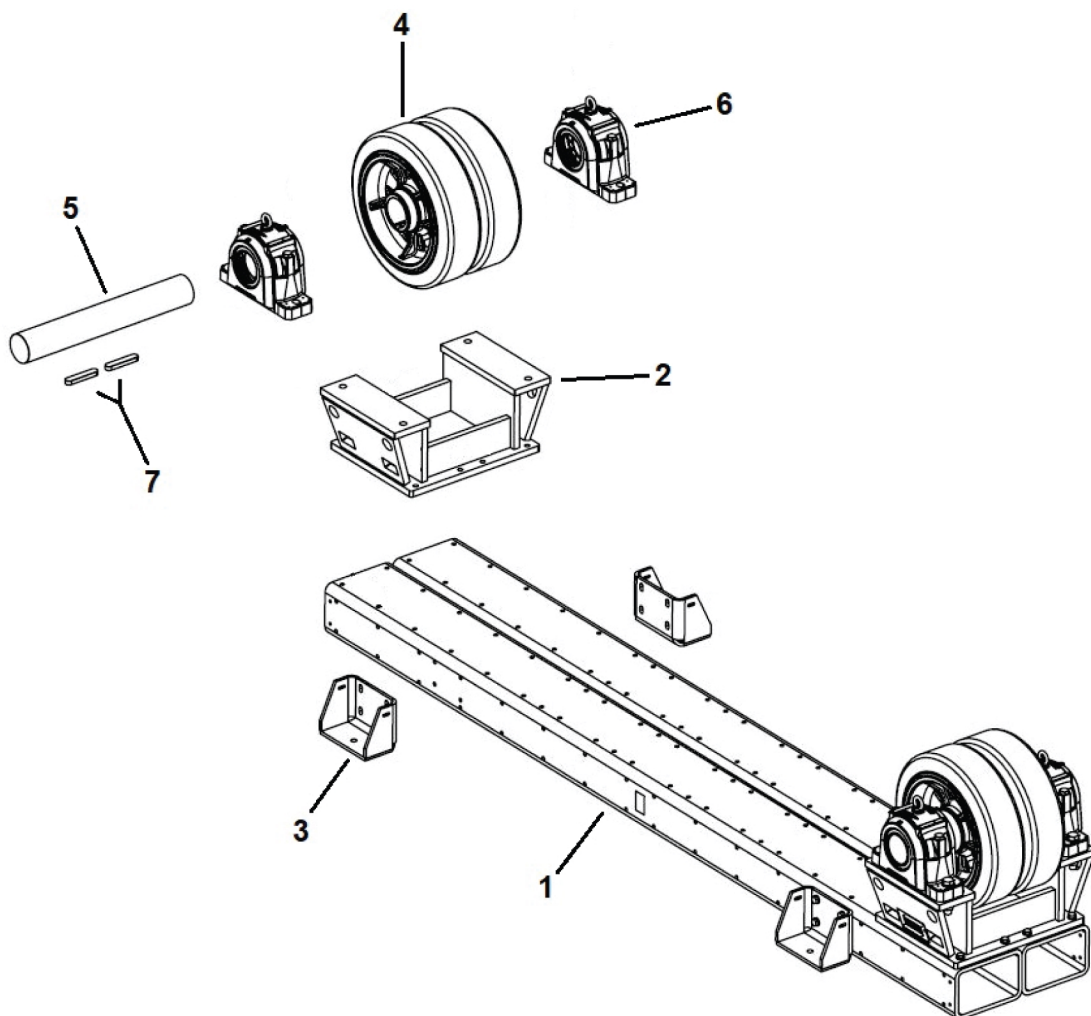

## SPARE PARTS - Control cabinet

Item	Qty	Ordering no.	Denomination	Marking	Notes
1	1	0908 800 209	Circuit breaker	A2	3P 10A C
2	2	0805 586 002	Contactora	A7.5 & A7.6	24 VDC
3	1	0908 800 400	Power supply DC	A4	24VDC/5A, 3AC400
4	1	0451 385 108	Safety relay, SSR10	A24	24 VDC
5	1	0908 800 202	Circuit breaker	A3	1P 4A C
6	1	0909 551 885	CPU and software ECD 7.5	A10	
	1	0909 500 885	CPU and software ECD 15	A10	
	1	0909 501 885	CPU and software ECD 30	A10	
	1	0909 502 885	CPU and software ECD 60	A10	
	1	0909 503 885	CPU and software ECD 90	A10	
	1	0909 504 885	CPU and software ECD 120	A10	
7	1	0909 551 885	Inverter w. configuration ECD 7.5	A5	0.55 kW
	1	0909 500 886	Inverter w. configuration ECD 15	A5	0.55 kW
	1	0909 501 886	Inverter w. configuration ECD 30	A5	0.75 kW
	1	0909 502 886	Inverter w. configuration ECD 60	A5	1.1 kW
	1	0909 503 886	Inverter w. configuration ECD 90	A5	2.2 kW
	1	0909 504 886	Inverter w. configuration ECD 120	A5	2.2 kW
8	2	0908 800 304	Motor circuit breaker, ECD 7.5	A6.1 and A6.2	1.1–1.6 A
	2	0908 800 302	Motor circuit breaker, ECD 15	A6.1 and A6.2	0.7-1.0 A
	2	0908 800 303	Motor circuit breaker, ECD 30	A6.1 and A6.2	0.9–1.25 A
	2	0908 800 304	Motor circuit breaker, ECD 60	A6.1 and A6.2	1.1–1.6 A
	2	0908 800 306	Motor circuit breaker, ECD 90	A6.1 and A6.2	1.8–2.5 A
	2	0908 800 307	Motor circuit breaker, ECD 120	A6.1 and A6.2	2.2–3.2 A
9	4	0452 116 008	Socket	A8.1, A8.2, A8.3, A8.4	
10	4	0452 116 004	Relay	A8.1, A8.2, A8.3, A8.4	5A/250A AC 5A/30V DC
11	1	0802 524 553	ProfiNet	A20	ET200SP
12	4	0802 524 556	Back plan module	A21–A23	ET200SP
13	2	0802 524 562	Digital input module	A21.1 and A21.2	ET200SP
14	1	0802 524 575	DO 16X24VDC	A22	ET200SP
15	1	0802 524 589	AQ 2xU	A23	ET200SP
16	3	0802 083 009	Terminals	X1	L1, L2, L3
17	2	0805 586 002	Motor contactor, rollers	A7.1 and A7.2	24 VDC
18	2	0805 586 002	Motor Contactora, rail car (opt.)	A7.3 and A7.4	24 VDC
19	7	0802 083 022	Earthing terminals	X1 and X2	PE

APPENDIX

Item	Qty	Ordering no.	Denomination	Marking	Notes
20	5	0802 083 081	Terminals	X2	+ 24 VDC
21	4	0802 083 081	Terminals	X2	0 VDC
22	1	0802 524 505	AO card, digital display	X10.2	If applicable

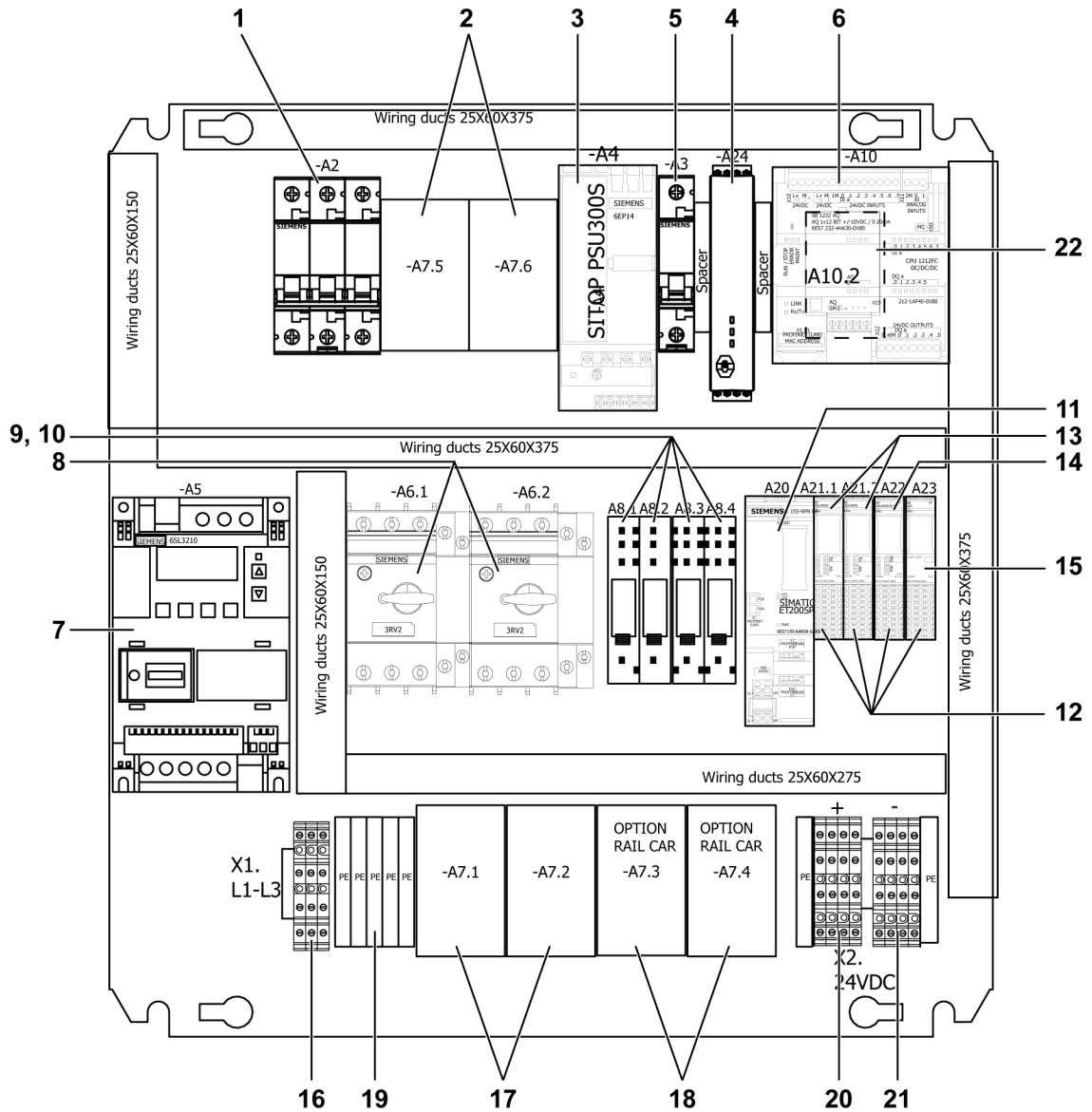

## SPARE PARTS - Electrical parts - Control cabinet

Item	Qty	Ordering no.	Denomination	Marking	Notes						
1	1	0908 800 001	Mains switch	A1	3P 16A						
2	1	0908 800 100	Emergency stop button	A30							
3	1	0908 800 111	Illuminated pushbutton, WHITE	A32	22MM 1NO						
4	1	0908 800 115	Illuminated pushbutton, RED	A31	22MM 1NO						
5	1	0908 800 114	Illuminated pushbutton, BLUE	A34	22MM 1NO						
6	1	0908 800 113	Illuminated pushbutton, GREEN	A33	22MM 1NO						
7	1	0909 530 950	Plug, male	1XP1							
8	1	0909 530 951	Plug, female	1XS2		9	1	0900 500 887	Digital display with configuration	A35	Optional
9	1	0900 500 887	Digital display with configuration	A35	Optional						

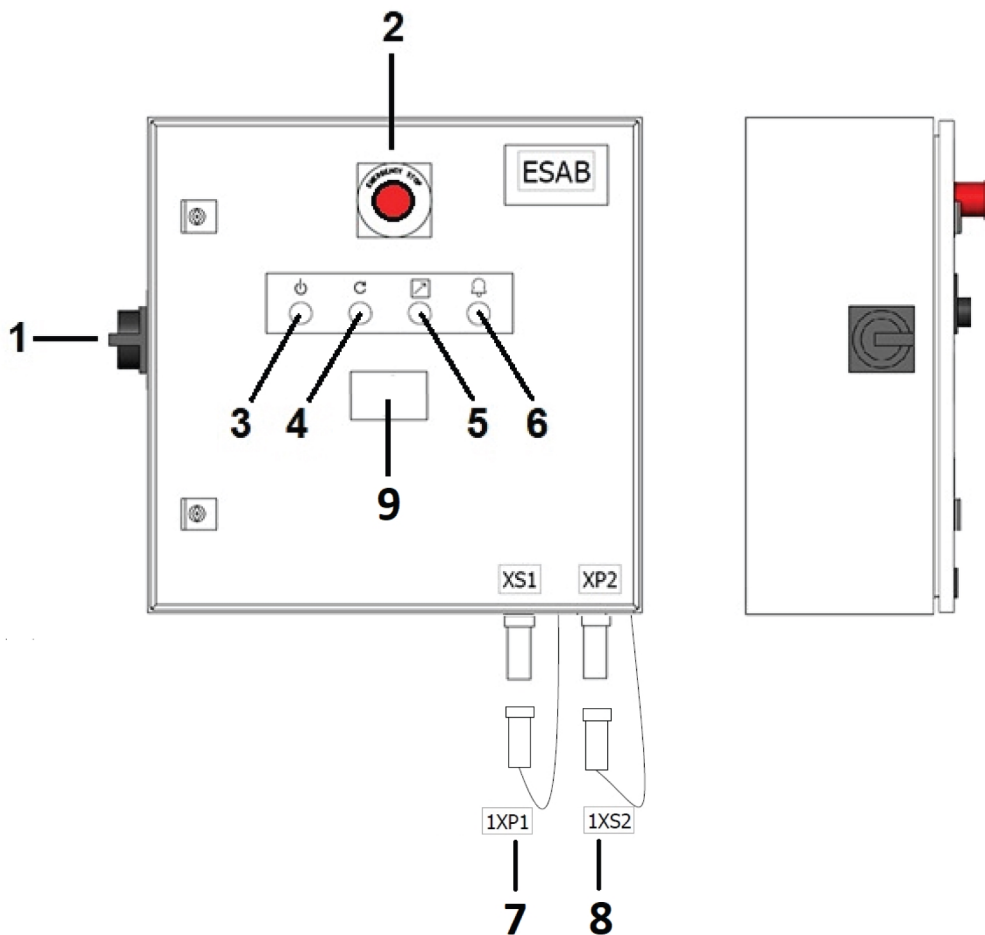

## SPARE PARTS - Wireless control system

Item	Qty	Ordering no.	Denomination	Notes
1	1	0909 500 903	Complete transmitter unit	

Wireless remote-control pendant

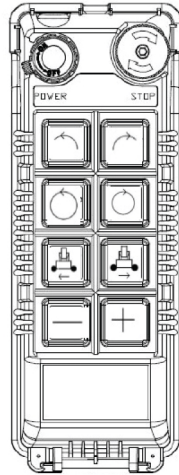

Charger

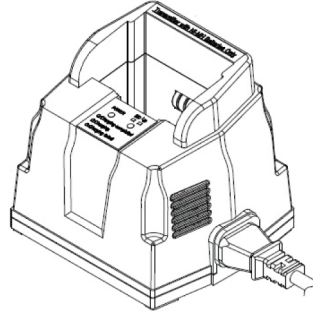

Receiver

FRONT VIEW

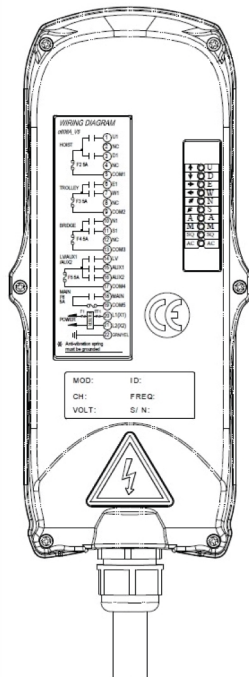

BACK VIEW

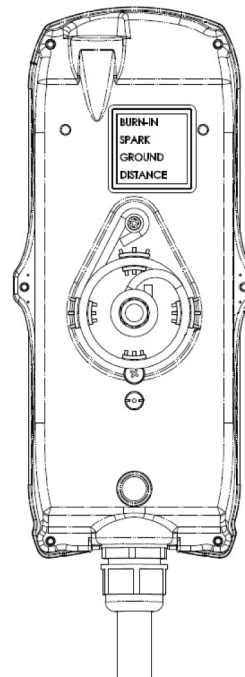







# A WORLD OF PRODUCTS AND SOLUTIONS.



For contact information visit <http://esab.com>

ESAB AB, Lindholmsallén 9, Box 8004, 402 77 Gothenburg, Sweden, Phone +46 (0) 31 50 90 00

[manuals.esab.com](http://manuals.esab.com)



CE

